

Chairside restorations without compromise.

Z4 – the smart practice solution for wet processing
of blocks and titanium abutments.



■ HIGH END CLASS

More than just state-of-the-art. Pioneering.

The leading technology of tomorrow. Available today.

Perfect restorations in no time at all

Your patients expect perfect results from you. With this in mind, vhf has developed the Z4 in the **HIGH END CLASS**, setting unprecedented quality standards for chairside restorations. With this machine, you can grind and mill reliably in the micrometer range – thanks to sophisticated drive technology and the precision-balanced high-frequency spindle. Its rotational speeds of up to 100,000 rpm and optimized machining strategies ensure record-breaking grinding times that further increase the efficiency of your practice.

But that's not all: The Z4 combines quality and speed with intuitive operation. This machine fits seamlessly into your workflows and can be operated with the integrated touchscreen by all employees after just brief instruction. This means that the Z4 can be integrated into your practice routine without any additional effort.

Intuitive working means everything runs perfectly

When the Z4 starts or finishes a job, the working chamber door opens and closes automatically. The drawer with the cooling liquid tank and tool magazines is also self-opening and can be operated by the touch display

– 100% intuitively. The capacitive display can even be operated with gloves. This is not only practical, but also saves you valuable time.

The future belongs to chairside restorations

The digital workflow enables faster treatments with first-class dental restorations in just one session. And the Z4 is more than just a machine, it is a statement in its own right: uncompromisingly advanced and at the cutting edge. This modern monolith will be a real eye-catcher in your practice. Thanks to its built-in compressor, the Z4 can be placed anywhere to attract the attention of your clients.

Openness has always been part of vhf's DNA. And that goes in all directions: Combine the Z4 with the intraoral scanner or CAD software of your choice and select the material that best suits your patient. We are constantly expanding the number of machinable block and abutment materials.

Your digital workflow: integrated or open?

Scan, design, mill. Everything in your practice.

Integrated workflow with 3Shape and exocad

With the Z4's integrated workflow, you work from the intraoral scanner to the milling machine with a single user interface. The exocad ChairsideCAD and TRIOS Design Studio (3Shape) software packages make all this possible.*

Unlimited possibilities with open STL workflow

Design in your own practice or in your favorite laboratory for maximum indication and material diversity and then transfer the data in STL format.

* In the 3Shape Produce workflow, nesting is done in vhf chairside-cam, thereby extending the range of functions and materials.



1. Scan



2. Design*



3. Mill



1. STL



2. Nest



3. Mill

The vhf academy: Learning made easy

For the first three months after purchase, we offer all customers free, four-hour online training sessions with a vhf application specialist. The training can be

held in either English or German. This enables you to quickly unlock the full potential of your new Z4.



With the Z4 vhf finally got everything perfect.



Prof. Dr. John A Sorensen
University of Washington,
Seattle/USA

Passion for Perfection

The **HIGH END CLASS** in routine use



All those who always strive for the best should watch our video series "Passion for Perfection". In this exclusive web series, Dr. Michael DiTolla asks six of the most respected dentists what roles their vhf machines play.

Are you still clamping or are you already milling? With our vhf directblock Technology, you can clamp the block in just seconds – no tools required. It couldn't be easier or more convenient.

Compelling arguments? Lots of them!

The key features of the Z4.

Fast & precise

- Milling and grinding in ultra HD
- 100,000 rpm electrical high-speed spindle
- Automatic changer for six tools
- 3 µm repetition accuracy
- Industrial-grade quality with machine bed made of a solid cast body for the lowest vibrations
- 100% developed and manufactured in Germany

Independent

- Around 40 machinable block materials and over 800 prefab titanium abutments from many manufacturers
- Validated for all common scanners and CAD software types
- Integrated workflows with exocad and 3Shape*
- Integrated touchscreen and interface computer
- Built-in compressor – no external compressed air supply required

Cost-effective

- vhf purewater Technology: no grinding additives required – except for titanium processing
- directblock Technology: block clamping in seconds
- Milling screw-access channels – saves costs for meso blocks
- Ultra-easy operation with dentalcam and its open interface to CAD software and materials
- Tool starter set included

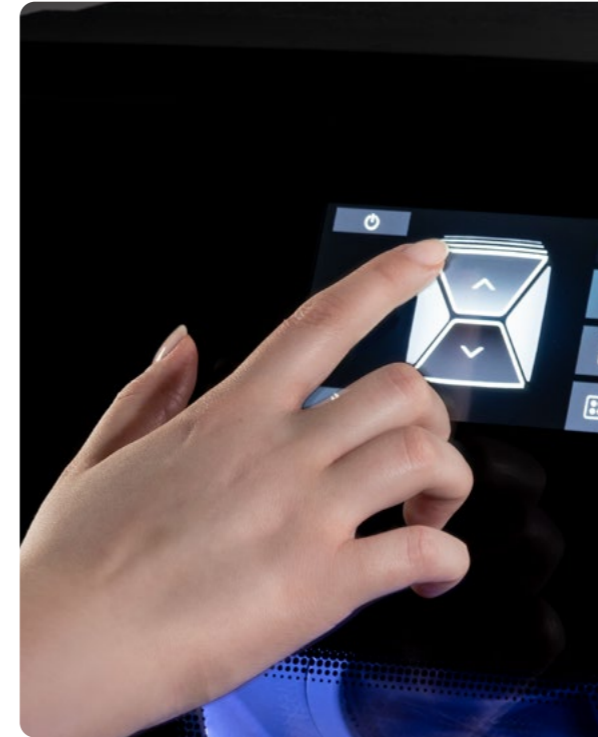

You can easily start processing your job with the touch display.



vhf also offers an impressive selection of abutment holders for all common systems.

* Material and indication availability may vary by CAD provider. Full range of indications and materials available in STL workflow.



In your Z4, you can grind or mill up to three-unit bridges without the need for grinding additives – thanks to purewater Technology.

Material, manufacturer, indication.

Enjoy the freedom of choice.**

Crown Bridge	Inlay Onlay	Veneer	Composites
Occlusal splint	Full denture	Denture-framework	Plastics Wax
Implant bar	Abutment	Screw-retained crown	Glass ceramics
Screw-retained bridge	Surgery guide	Primary crown	Zirconia
Secondary crown	Model plate	Model tooth die	Titanium
			CoCr

** Be sure to review local and/or national regulations and/or regulations by other authorized organizations or entities (e.g. professional associations, health authorities).

Did you know?

Study: Z4 drills screw-access channels in the highest quality

A scientific study at the University of Washington proved a key feature of the Z4. Using the Z4 milling and grinding machine, dental professionals can easily drill screw-access channels for hybrid implant restorations into ceramic blocks with no significant difference in flexural strength compared to factory-pre-drilled “meso” blocks. In fact, such “meso” blocks are significantly more expensive and their nesting process more challenging. Therefore, processing standard blocks with the Z4 means that the user has lower costs for material, a smaller material inventory and easier nesting.

Quelle: Jack M. Keesler, DDS, MSD: Effect of milling screw-access channels on flexural strength CAD/CAM ceramic materials. MSD Master's Thesis, University of Washington, 2019.



Technical data

General

Fields of application: Wet machining

Materials: Glass ceramics, titanium, zirconia, composites, plastic materials · blocks up to 45 × 20 × 20 mm

Indications: Crowns, bridges, fully anatomical crowns and bridges, inlays, onlays, abutments, veneers, table tops

Warranty: 24 months/2,000 hours of operation (whichever comes first)

Base system

Construction: Machine bed made of solid cast aluminum body

Housing: Thick-walled TSG injection molding, white high-gloss lacquer finish with workspace flap and combined drawer for cooling liquid/tool inserts

Number of axes: 4

Linear axes (X-/Y-/Z-axis): Precision ball screws · motors with resolution < 1 µm · ground precision steel guides · repetition accuracy ± 0.003 mm

Rotary axis (A-axis): Rotary axis with high concentricity · rotation angle: 200°

Control unit: 4-axis simultaneous control electronics with continuous path progression and dynamic pre-calculation · hardware-based real-time operating system with standardized command set · FPGA-integrated processor · updateable hardware · real-time path calculation via dedicated hardware engines in the FPGA · four-quadrant control of the motors for particularly smooth running · multiple analogue and digital I/Os for controlling the peripherals · integrated inverter for synchronous and asynchronous motors, electronic gate detection · Ethernet and USB interface

Compressed air generation: Internal compressed air supply with integrated sound insulation

Lighting: RGB LED lighting with status display

Camera system: Integrated in the working chamber for easy remote support and possibility of internal recording

Display: Capacitive 5-inch touchscreen display fully integrated into the front flap for local operation of the machine.

Spindle

General: High-frequency spindle, asynchronous with pneumatic tool clamping · sealing air to prevent debris from entering · automatic cone cleaning

Speed: Up to 100,000 rpm

Power: Peak power (P_{max}): 330 watts · nominal power (S6): 210 watts · continuous power (S1): 170 watts

Bearing: Hybrid ceramic ball bearing · concentricity deviation at inner cone < 2 µm

Collet: Stainless steel collet with ceramic coating for tools with a shank diameter of 3 mm and max. 35 mm total length

AUTOMATION

Tool change: Tool magazine for 6 tools, removable and material-coded · Length measurement and tool monitoring control via precision measuring key

Workpiece change: The integrated vhf directblock Technology automatically takes over the clamping and releasing of the block or abutment holder to be machined

Access to working chamber: Motorized opening and closing of the work chamber flap, movement parallel to the chassis

Access to combined drawer: Electric ejector for tool and cooling liquid tank drawer

PROCESSING MODE

Wet: Multiple liquid nozzles on the spindle · Integrated cooling liquid (2 liters) with active carbon filter system · flow-sensor for monitoring the liquid supply · purewater Technology: no grinding additives except for titanium processing

Connection requirements

Compressed air: No compressed air required

Power supply: 100 – 240 volts · 50/60 Hz, 750 watts

Data: 10/100/1000 MBit/s BaseT port (auto-sensing) Ethernet via RJ-45 socket

Environmental conditions

Operating temperature: Between 10 °C and 35 °C

Air moisture: Max. 80 % (relative), non-condensing

Approvals

All models: CE, VDE

North America model: UL, FCC (according to ANSI/UL 61010-1)

Dimensions & weights

Dimensions (W/D/H): 471 × 521 × 507 mm ·

471 × 743 × 608 mm with open flap and drawer

Footprint (W/D): 400 × 305 mm

Weight: 66 kg

Scope of delivery & accessories

CAM-Software: vhf dentalcam

Holder systems: Abutment holder devices for various systems (optional)

Accessories: Control PC with mounting material for machine rear panel · spindle service set · calibration set incl. micrometer · brush for nozzle plate · cleaning brush · microfiber cloth · spare fine filter · active carbon pellets · Tec Powder (3 bags) · spare wiper for viewing window · tool magazine inserts (5 pieces) · torque wrench · 2 Allen wrenches · drill bit (tool positions) · measuring pin · power cable · Ethernet network cable · carrying aid for transporting the machine · operating instructions

Subject to changes and errors.

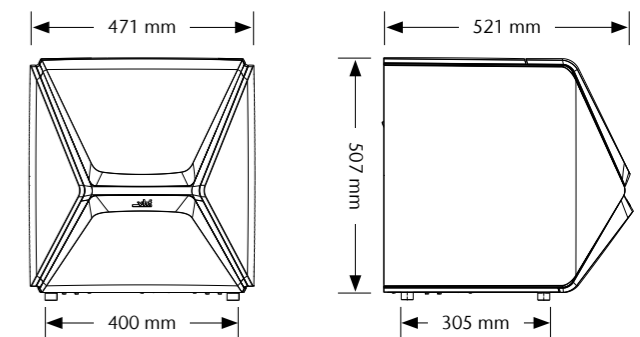

The HIGH END CLASS at a glance.

For the ultimate user experience.

The two **HIGH END CLASS** machines are our highly automated top-of-the-line models that give you the ultimate user experience!

The **Z4** is the smart practice solution for chairside fabrication of restorations from block materials and prefabricated abutments within an integrated workflow.

The **R5** is the vhf flagship machine, featuring the greatest possible flexibility for practice and lab in the hybrid workflow thanks to an automated switch between wet and dry processing and its material changer for discs, blocks and abutments.



CREATING PERFECTION.

vhf – synonymous with innovation and perfection since 1988.

With over 35 years of experience in mechanical engineering, vhf is one of the leading manufacturers of dental milling machines. As a full-service CAM provider, vhf carefully develops and produces every single milling machine as well as the perfectly matched tools and software completely in-house. Everything from a single source. Made in Germany.

Service. A matter close to our hearts.

Despite their short maintenance intervals and particularly long service lives, servicing your machines is very important to us. We support you with our user-friendly dental **portal**, numerous online tutorials and personal support through our international service network.



EN
DE
FR
IT
ES
CN

As of: 10/2025 · No. 269572

EN

vhf camufacture AG

Lettenstraße 10
72119 Ammerbuch
Germany
+49 7032 97097 000
info@vhf.de | vhf.com

North America

vhf Inc.
80 Davids Drive, Suite 5
Hauppauge, NY 11788, USA
+1 631 524 5252
info@vhf.com | vhf.com

Asia

vhf Trading (Shanghai) Co., Ltd.
Room 2902, Building T1, Tianshan SOHO,
No. 421 Ziyun Road, Changning District,
Shanghai, China
asia@vhf.de | vhf.com

vhf
CREATING PERFECTION