

# Aligner manufacturing in assembly-line style.

The specialist in the processing of  
thermoformed dental splints.



■ EASE CLASS

**vhf**  
CREATING PERFECTION

# Automate your trimming workflow.

Manufacture entire aligner series in the shortest possible time.

## More convenience in splint manufacturing

The E3 enables you to automate the precision trimming of all types of thermoformed dental splints. Enjoy optimum results in the shortest possible time. The machined fabrication also allows you to ensure consistently high quality.

## Automate your workflow.

The E3 is simple to commission and operate, and fits seamlessly into your workflows. Our trimcam software automatically recognizes from the available planning data the trim line on which the splint is milled out. So you can hit the ground running. True to the motto: Unpack, turn on, start milling!

## Maximum flexibility and optimum results

At a machine weight of just 25 kg and without the use of compressed air, the compact E3 offers maximum flexibility at the installation site. Meticulous attention has been paid to the details: For example, you don't need separate air extraction – thanks to the practical collection tray for chips.

## Industrial-grade quality made in Germany

100% developed and manufactured in Germany, the E3 delivers impressively precise results and maximum reliability – not only for aligners, but also for bite splints, grinding splints and other types of splints, including sports mouthguards. Despite its compact design, only high-quality industrial components are inside.

## Service made easy

If a service case occurs, central components such as the spindle are easy to replace – if you wish, you can even do it yourself in just a few flicks of the wrist.

With the E3, you can produce aligner series in the shortest possible time – without any significant pre-processing or rework.



The E3 workflow automates the bulk of aligner fabrication. Without unnecessary repetition or tedious manual work.



Dr. Chris Silvoy  
Dentist, Durham, North Carolina, USA



The tool-free clamping system makes your work even easier. This quick blank change enables you to manufacture entire series of aligners in no time at all.

# Compelling arguments? Lots of them!

The key features of the E3.

## Fast & precise

Powerful 800 W spindle with 60,000 RPM

Sturdy aluminum-welded construction

Tool-free fixation of the thermoforming sheet almost instantly

Complete processing of aligners in approx. 45 seconds

Made exclusively of high-quality industrial components

100% developed and manufactured in Germany

## Independent

Quickly and easily cut out thermoformed dental splints from different material manufacturers

Machine design optimized for low weight

trimcam software with open interface to planning software

Modular design for service-optimized maintenance

## Cost-effective

Sustainable operation with no compressed air

Environmentally friendly shipping by parcel service is possible thanks to the low machine weight

The excellent price-performance ratio ensures a cost-effective entry into CNC fabrication

Ultra-easy operation with trimcam software and its automatic trim line recognition



# Material, manufacturer, indication.

Enjoy the freedom of choice.\*

Crown   Bridge	Inlay   Onlay	Veneer	Composites
Occlusal splint	Full denture	Denture-framework	Plastics Wax
Implant bar	Abutment	Screw-retained crown	Glass ceramics
Screw-retained bridge	Surgery guide	Primary crown	Zirconia
Secondary crown	Model plate	Model tooth die	Titanium
			CoCr

\* Be sure to review local and/or national regulations and/or regulations by other authorized organizations or entities (e.g. professional associations, health authorities).

# With trimcam to the perfect aligner.

The specialized software from vhf supports the automated fabrication of all types of dental splints.

The trimcam software developed in-house at vhf enables you to fabricate your dental splints conveniently and easily. The trimcam workflow supports you from the moment you import the 3D data on the dental arch model from your CAD application. From this data, trimcam automatically calculates the trim line you can apply to further customize as needed. This step is followed by preparation for 3D printing of the dental arch model and precision milling of the thermoforming sheet thermoformed by this model.

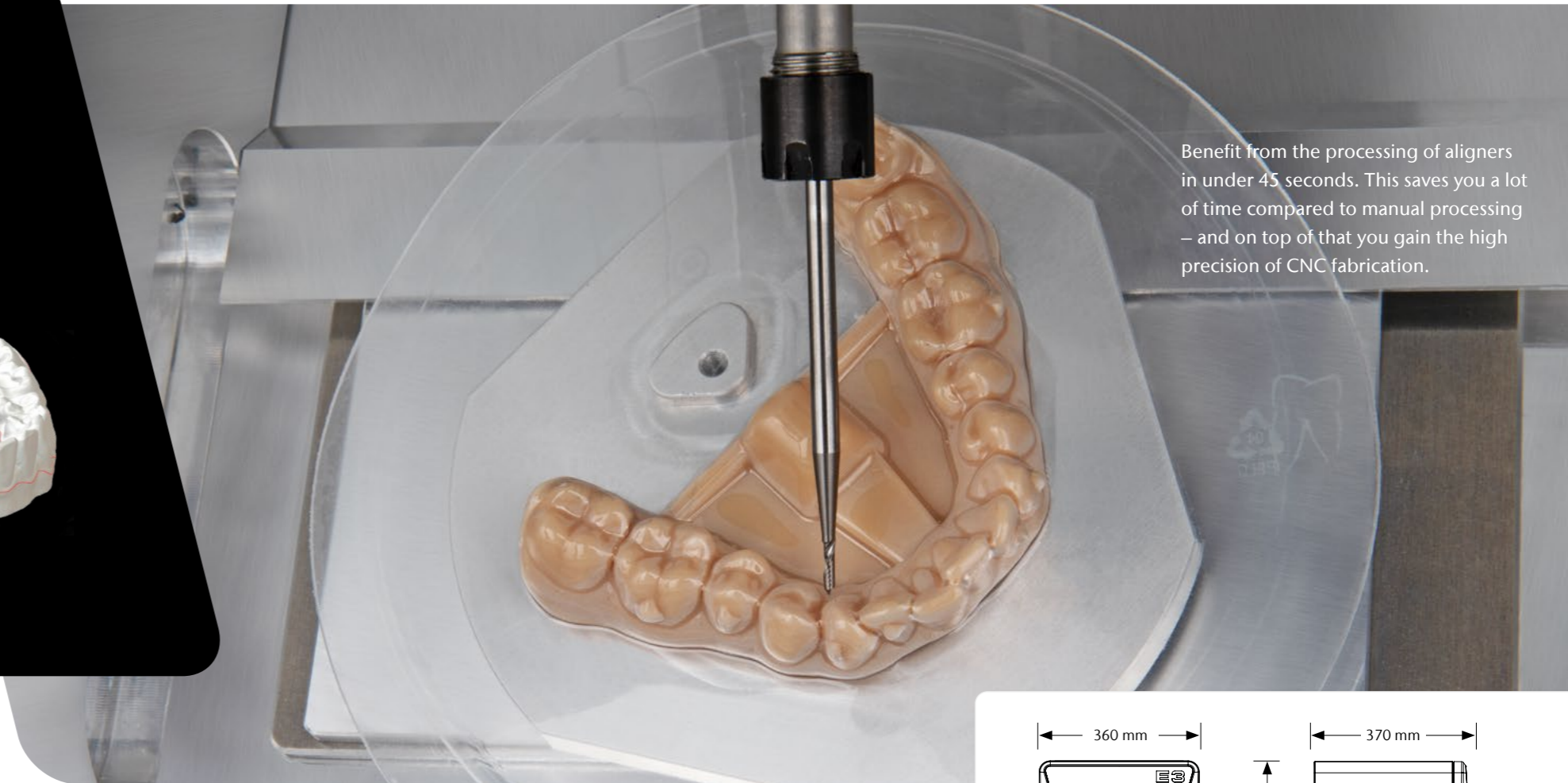

Benefit from the processing of aligners in under 45 seconds. This saves you a lot of time compared to manual processing – and on top of that you gain the high precision of CNC fabrication.

## Technical data

### General

**Fields of application:** Dry machining

**Materials:** Thermo-formed plastic foil

**Indications:** Aligners and other splints

**Holder systems:** Holder for tool-free clipping in of the aligners

**Warranty:** 24 months/2,000 hours of operation (whichever comes first)

### Base system

**Construction:** Sturdy aluminum structure

**Housing:** White high-gloss lacquer finish · upward opening lift door to the workroom

**Number of axes:** 3+1

**Linear axes (X-/Y-/Z-axis):** X-axis: rack and pinion drive · Y-/Z-axis: trap-ezoidal screw spindles · motor resolution 10 µm · max. axial backlash 0.06 mm

**Rotary axis (B-axis):** Drehwinkel: 360°, unendlich

**Control unit:** Control electronics with continuous path progression and dynamic pre-calculation · hardware-based real-time operating system with standardized instruction set · FPGA-integrated processor · updateable hardware · real-time path and ramp calculation via dedicated hardware engines in the FPGA · four-quadrant control of the motors for particularly smooth running · multiple digital I/Os for controlling

the peripherals · integrated inverter for synchronous and asynchronous motors, electronic gate detection · Ethernet and USB interface

**Lighting:** RGB LED lighting with status indication

### Spindle

**General:** High-frequency spindle with mechanical tool change

**Speed:** Up to 60,000 RPM

**Power:** Peak power ( $P_{max}$ ): 800 watts · continuous power (S1): 450 watts

**Bearing:** 2-fold hybrid ceramic ball bearing

**Collet:** Collet type ER8 for tools with 3 mm shank diameter

### Processing mode

**Dry:** Compressed air-free operation without suction

### Connection requirements

**Compressed air:** –

**Power supply:** 100–240 volts · 50/60 Hz, 320 watts

**Data:** 10/100/1000 MBit/s BaseT port (auto-sensing) Ethernet via RJ-45 socket

### Environmental conditions

**Operating temperature:** Between 10 °C and 35 °C

**Air moisture:** max. 80 % (relative), non-condensing

### Approvals

**All models:** CE

**North America model:** UL 61010-1, CAN/CSA C22.2 No. 61010-1

### Dimensions & weights

**Dimensions (W/D/H):** 360 × 370 × 490 mm with closed door · 360 × 420 × 490 mm with open door

**Footprint (W/D):** 286 × 268 mm

**Weight:** 25 kg

### Scope of delivery

**CAM software:** vhf trimcam for aligner production included

**Accessories:** Calibration set incl. stirrup measuring screw · Torx driver · torque driver 1.5 Nm · cleaning brush · cleaning scrubber and microfiber cloth · radius cutter (2 pcs.) · clamping wrench · open-end wrench · power cable · Ethernet network cable

Subject to changes and errors.

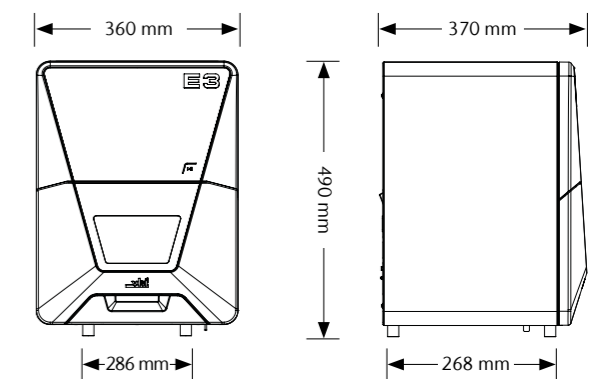

# The EASE CLASS at a glance.

Premium dental restorations made easy.

The **EASE CLASS** machines are notable for their ability to operate without compressed air, their compact design at a low weight and a service-friendly concept: Premium dental restorations made easy.

The **E3** is our specialized machine for the efficient trimming of thermoformed dental splints. It delivers first-class results in the shortest time – without complicated reworking.

The **E4** was specially developed for an easy entry into chairside production. As a wet grinding machine with a dry milling option, it enables the precise grinding and milling of blocks.

With the **E5**, our dry milling machine for discs and blocks, you can achieve milling results at the highest level and do so with extreme ease of use.



## CREATING PERFECTION.

**vhf – synonymous with innovation and perfection since 1988.**

With over 35 years of experience in mechanical engineering, vhf is one of the leading manufacturers of dental milling machines. As a full-service CAM provider, vhf carefully develops and produces every single milling machine as well as the perfectly matched tools and software completely in-house. Everything from a single source. Made in Germany.

**Service. A matter close to our hearts.**

Despite their short maintenance intervals and particularly long service lives, servicing your machines is very important to us. We support you with our user-friendly dental **portal**, numerous online tutorials and personal support through our international service network.



EN  
DE  
FR  
IT  
ES  
CN

As of: 10/2025 · No. 269612

EN

### vhf camfacture AG

Lettenstraße 10  
72119 Ammerbuch  
Germany  
+49 7032 97097 000  
info@vhf.de | vhf.com

### North America

vhf Inc.  
80 Davids Drive, Suite 5  
Hauppauge, NY 11788, USA  
+1 631 524 5252  
info@vhf.com | vhf.com

### Asia

vhf Trading (Shanghai) Co., Ltd.  
Room 2902, Building T1, Tianshan SOHO,  
No. 421 Ziyun Road, Changning District,  
Shanghai, China  
asia@vhf.de | vhf.com

**vhf**  
CREATING PERFECTION