

MAX 2

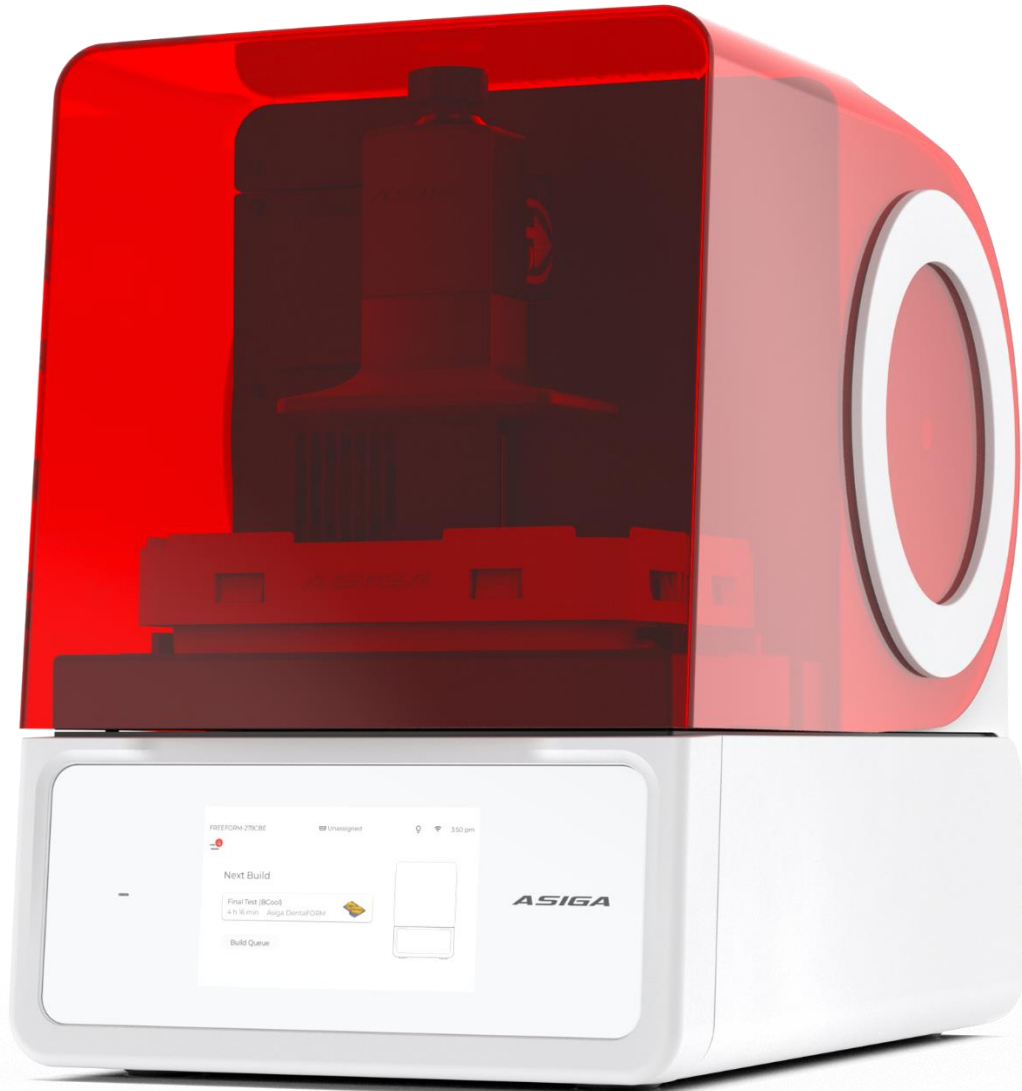

ASIGA

USER GUIDE

Index

Index	2
CHAPTER 1 Device Information	4
Intended Purpose	4
Contraindications	4
Legal Manufacturer and Australian Sponsor Details	5
CHAPTER 2 Asiga MAX 2 at a Glance	6
Principle of Operation	7
Transparent mode	9
CHAPTER 3 Getting Started	10
Unpacking	10
Location	10
Power On	10
Choose your Language	11
Register the printer	11
Connect to a network	13
Platform Calibration	13
Zero Position Encoders	17
Network Connection	19
Ethernet Setup	19
Wireless Setup	19
Wireless Direct Setup	19
Install Composer Software	20
CHAPTER 4 Starting a Build	21
Installing the Material Tray	21
Add Resin to the Material Tray	21
Clean the Material Tray Bottom	21
Set the Chamber Temperature	23
Starting the Build	24
Next Build	24
Build Queue	25
Build checklist	25
Build screen	25
Auto-shutdown	26
One-time event	26
Permanent auto-shutdown	26
Diagnostic Data	26
Stopping and Pausing the Build	27

CHAPTER 5	Web Interface	28
	Accessing the Web Interface	28
	Build Queue Tab	28
	Front Panel Tab	30
	Settings Tab	30
	System Information Tab	31
	Update Firmware Tab	33
	Support Tab	33
	Restricted Mode	34
	Policy Editor	35
CHAPTER 6	Post-processing Parts	37
	Removing Parts from the Build Platform	37
	Washing Parts	37
	Post-Curing Parts	38
CHAPTER 7	Maintenance and Calibration	39
	Service Mode	39
	Zero Position	39
	Projector	39
	Sensors	40
	Material Analysis	41
	Viscosity Analyzer	41
	Clear User Data	42
	Platform Calibration	43
	Validate Parallelism	43
	Service Mode	47
	Film Thickness	48
	Calibrate Radiometer	49
	Normalize Radiometer	51
	Calibrate Position Encoders	53
	Calibrate Deflection	55

CHAPTER 1 **Device Information**

Asiga's 3D printers build objects from liquid photopolymers by successively hardening the material in fine layers with the aid of light. The design objects are supplied to the printer in the form of digital CAD files. Printed objects can be arbitrary shapes and produced from a variety of biocompatible materials which may be used in medical applications.

Asiga 3D printers are mainly used to build parts for Audiology and Dental devices.

Audiology devices include:

- **Hearing Aid Body:** A customised hollow shell component, designed to fit patient's ear canal for housing electronic components to assist hearing.
- **Hearing Aid Ear Mould:** A solid plug with acoustic vents, customised to fit patient's ear canal for routing sounds generated by a behind-the-ear hearing device to the patient's ear canal.
- **Hearing Aid Flexible Ear Mould:** A solid plug with acoustic vents, made by injecting silicone rubber into a 3D printed casting shell for routing sounds to a patient's ear canal.

Dental devices include:

- **Full Denture:** Comprising of a base and teeth both made on a 3D printer, worn by a patient during the day for eating and removed at night for cleaning.
- **Denture Try-In:** A single use, temporary denture used for less than 60 minutes in patient's mouth to verify denture geometry for comfort and fit.
- **Custom tray:** A single use, custom shaped plate used for less than 15 minutes in patient's mouth for holding dental silicone to obtain an impression of a patient's teeth.
- **Dental Splint:** Mouth guard worn on patient's teeth at night to alleviate bruxism.
- **Indirect Bonding Tray:** A single use flexible holder for holding orthodontic brackets in position while bonding them to a patient's teeth. The device is used for less 60 minutes in patient's mouth.
- **Surgical Guide:** Structure placed on a patient's teeth for mounting cylindrical metal sleeves that guide a dentist's drill when cutting spaces for dental implant screws. The device is for single use only and removed from patient's mouth in less than 60 minutes.

Intended Purpose

The Asiga 3D Printing System consists of 3D Printers, Resins, and UV Light Curing Lamp, intended to be used in the manufacture of Dental and Audiology devices for transient and short-term use only.

Indications

Dental: Removable denture prosthetics, functional try-in mock-ups for removable denture prosthetics, impression and functional trays for removable denture products, surgical guides for drill placement during dental surgery, bonding trays for application of orthodontic braces, removal dental night-guards to prevent bruxism.

Audiology: Customised hollow shell components designed to fit patient's ear canal for housing electronic components to assist hearing, customised ear moulds for guiding sound from behind-the-ear amplifiers, casting patterns for audiology ear moulds.

Contraindications

Audiology: Not suitable for infants below 36 months. Users of active implants must pay attention when using the hearing aid.

Legal Manufacturer and Australian Sponsor Details

Asiga Pty Ltd
Unit 2, 19-21 Bourke Road
Alexandria, NSW 2015
Australia Specification

Technical specifications

Build Volume X, Y, Z	119 × 67 × 75mm	4.69 × 2.64 × 2.95 inches
Pixel Resolution	62µm	
Technology	DLP	
Auto-calibrating UV LED	385nm (405nm available on request)	
Material Compatibility	Use any one of over 500 qualified resins from the world's leading material manufacturers, or create your own.	
Software	Asiga Composer software. Lifetime updates included	
File Inputs	STL, SLC, PLY, STM (Asiga Stomp file format)	
Network Compatibility	Wifi, Wireless Direct, Ethernet	
Power Requirements	100 to 240 VAC, 50/60 Hz, ≤2 Amps	
System Sizing	260 × 385 × 370mm / 19.3 kg	10.2 × 15.2 × 14.5 inches / 42.6 lb
Packed Sizing	410 × 500 × 480mm / 21.6 kg	16.1 × 19.7 × 18.9 inches / 47.6 lb
Warranty	12 months manufacturer's warranty	
Technical Support	Unlimited lifetime technical support included	
Bundle Includes	3D printer, Composer software, 1 kg Asiga material, 1L build tray, Asiga Flash post-curing chamber, calibration toolkit	

CHAPTER 2

Asiga MAX 2 at a Glance



Front

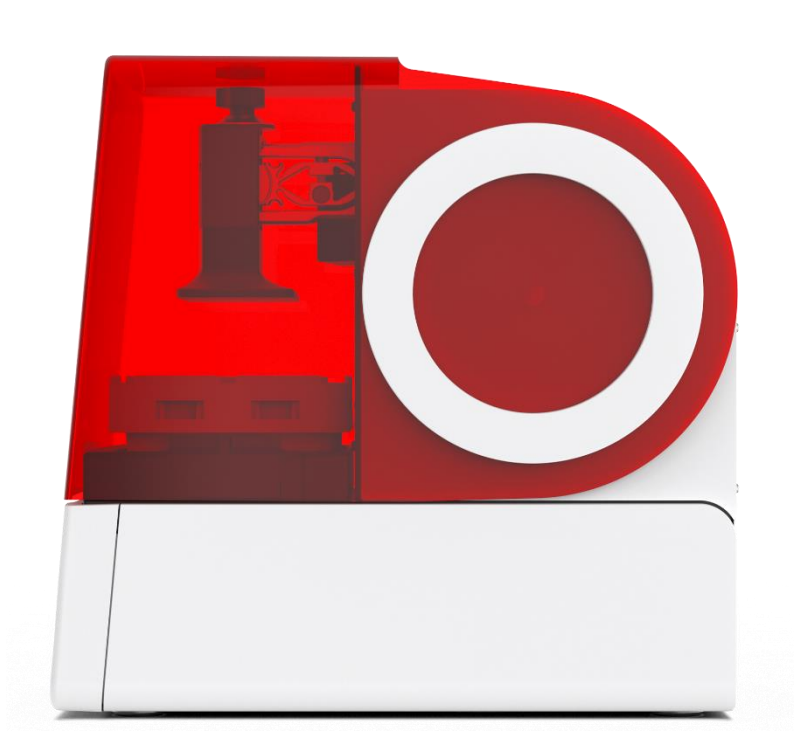

Side



Base

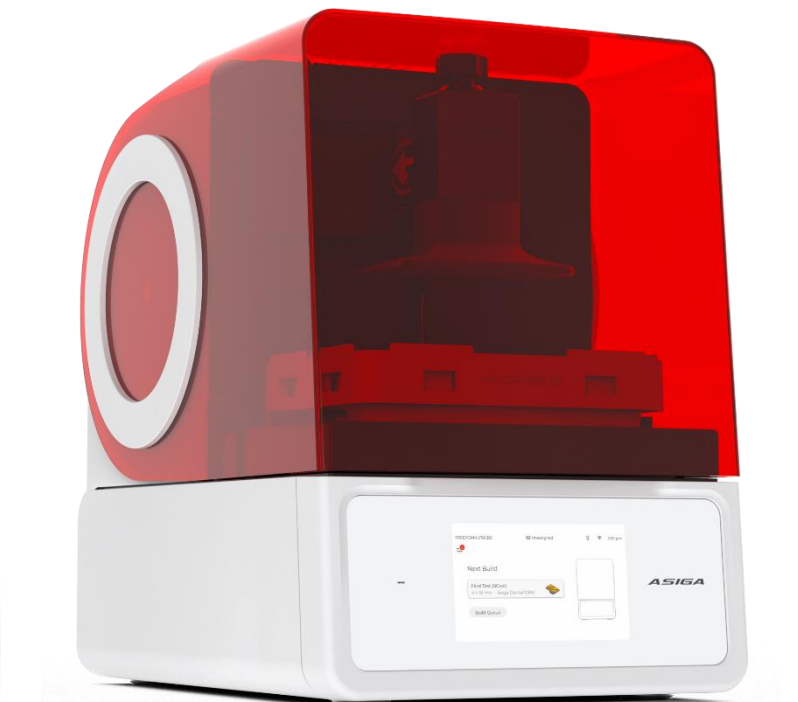

Ortho

Principle of Operation

The MAX 2 is a 3D printer which builds objects from CAD data. The objects are built from photopolymer resins which are liquid chemicals that can be solidified by exposure to light. A physical model is built by solidifying successive layers of photopolymer against each other. This process is called “stereolithography”.

The MAX 2 build process employs a unique feature which is referred to as the Smart Positioning System (SPS). The SPS utilizes an array of position encoders which detect when a layer of correct thickness is formed. The process works as follows:

1. The model under construction is positioned above the vat of photopolymer. The vat bottom is made from a flexible transparent Teflon film which is supported by a glass plate.

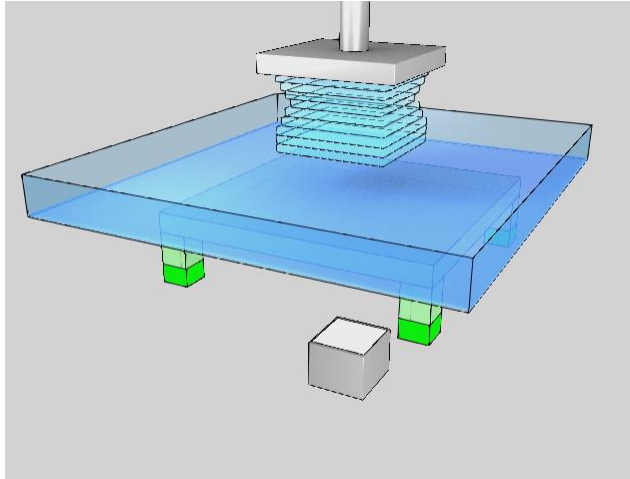

2. The model is moved downwards to one layer-thickness above the bottom of the vat. The movement squeezes photopolymer resin out from the gap between the model and the Teflon film. Viscous forces oppose the motion, resulting in mechanical deflection of the apparatus.

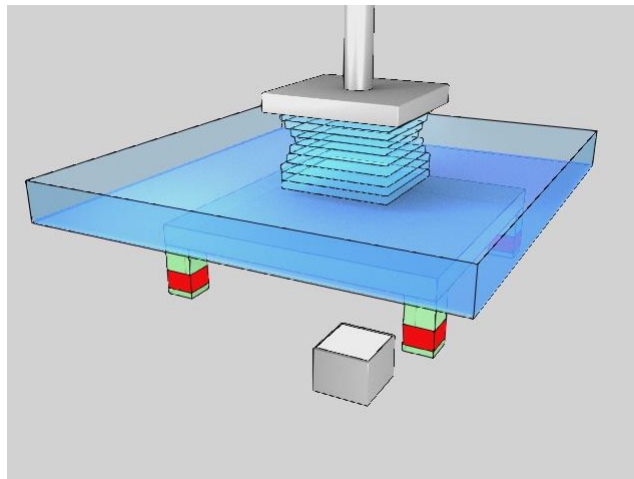

3. Four position encoders at each corner of the glass plate precisely monitor the mechanical deflection between the glass plate and the model under construction. The process monitors the deflection until it is relieved.

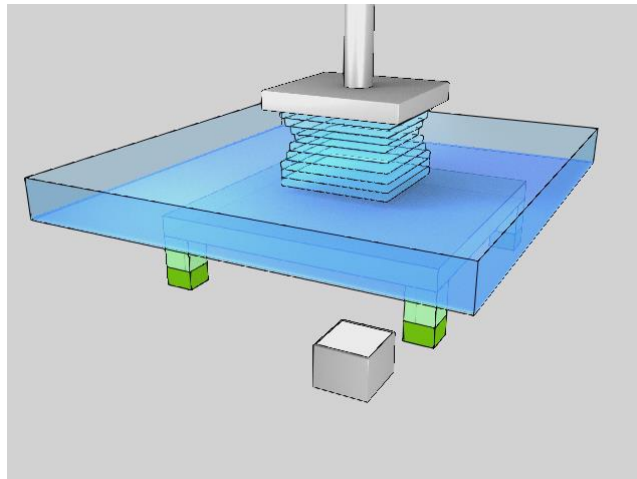

4. A cross-sectional image of the object being constructed is projected onto the underside of the vat film, causing photopolymer to harden in the shape of the image.

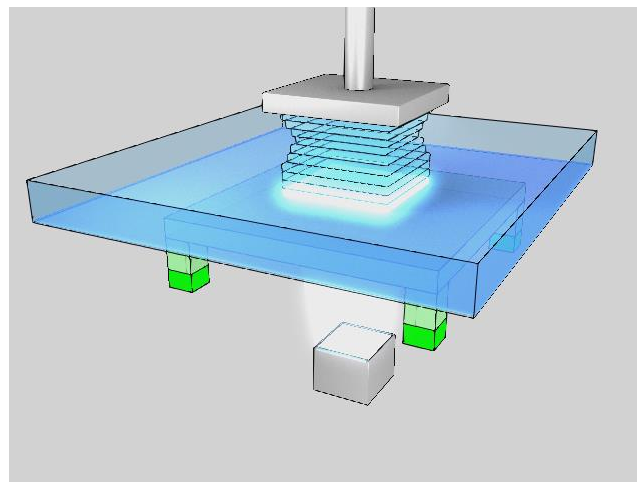

5. The model is lifted out of the vat to separate it from the vat film.

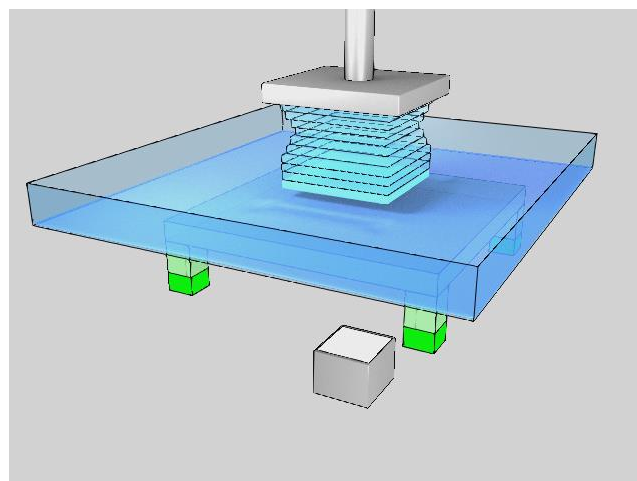

6. The process is repeated until the model has finished building.

The SPS process actively forms layers of precise thickness regardless of the cross-sectional area of the model or the viscous behavior of the photopolymer resin. As a result, models of high fidelity are produced. The MAX 2 is ideal for direct manufacturing applications including medical prostheses and jewelry pattern production.

Transparent mode

Transparent mode can improve the part resolution of transparent or water clear materials. This does not affect the immediate curing properties of materials, it may extend printing time. It is advised to use normal printing mode on materials that would not benefit from Transparent mode.

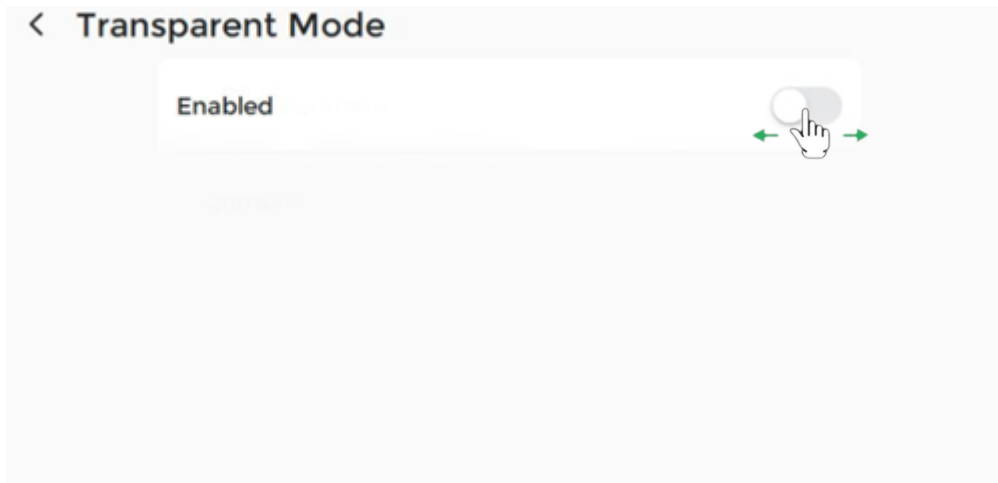

To enable Transparent mode, go to Settings > Hardware > Projector

Slide the toggle to enable.

CHAPTER 3 Getting Started

Unpacking

Refer to the MAX 2 unpacking guide. This is supplied with the machine.

Note the markings on the side of the box indicating which side is the top. Open the box top and remove the top film frame. Note that accessories may be packed inside the cardboard frame. Then left out the MAX 2 machine and place it on a flat table. Unwrap any protective film surrounding the MAX 2 machine.

Do not discard your box. Put it in a safe place should you need to transport your MAX 2 machine for any reason.

Location

Ensure your MAX 2 is placed on a flat table top with access to mains electricity. Avoid direct sunlight as this will degrade material left in the machine. The table top does not need to be perfectly level. Avoid vibrating surfaces.

Power On

Plug the power supply into the DC power input at the rear of the machine. The power supply is designed for input between 100 – 240V AC single phase.

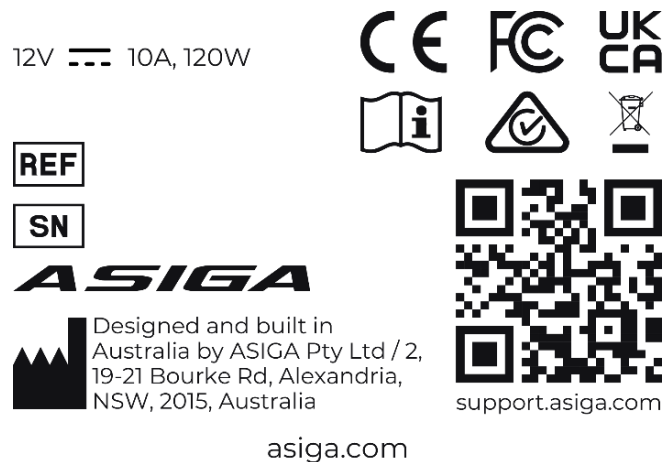

Turn on the MAX 2 machine by:

1. Flipping the power switch on the back of the machine to the ON position. You will see Standby Power LEDs on the back of the machine become illuminated.

IMPORTANT NOTE: TO SHUTDOWN THE MACHINE, ALWAYS DO SO VIA THE USER TOUCH SCREEN DISPLAY. NEVER SHUTDOWN USING THE POWER SWITCH. TO POWER OFF YOU CAN USE THE FLIP SWITCH BUT ONLY AFTER THE MACHINE HAS BEEN SHUTDOWN VIA THE USER TOUCH SCREEN DISPLAY.

2. Press the ON/OFF button at the top left of the machine. The LCD screen at the front of the MAX 2 will turn on. Within 15 seconds the user interface will become active. The user interface is an interactive touch-screen LCD.



Choose your Language

Upon initial start-up you will be given the option to select your language by scrolling through a list presented on the LCD screen.

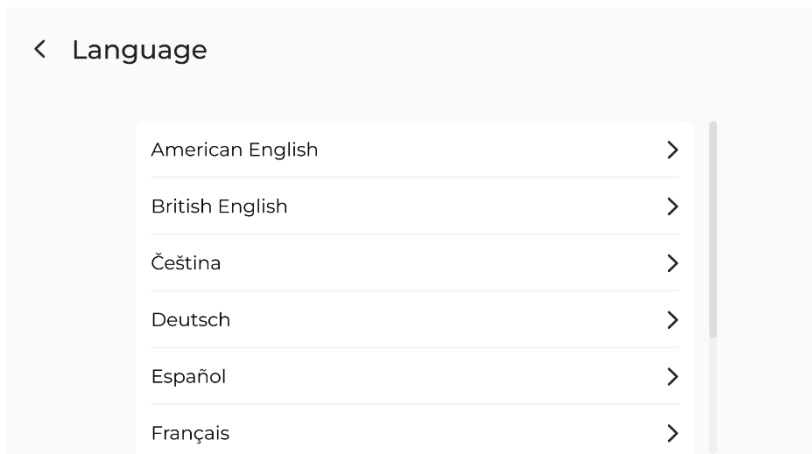

Register the printer

On first start up you will be presented with a screen to enter the warranty code.

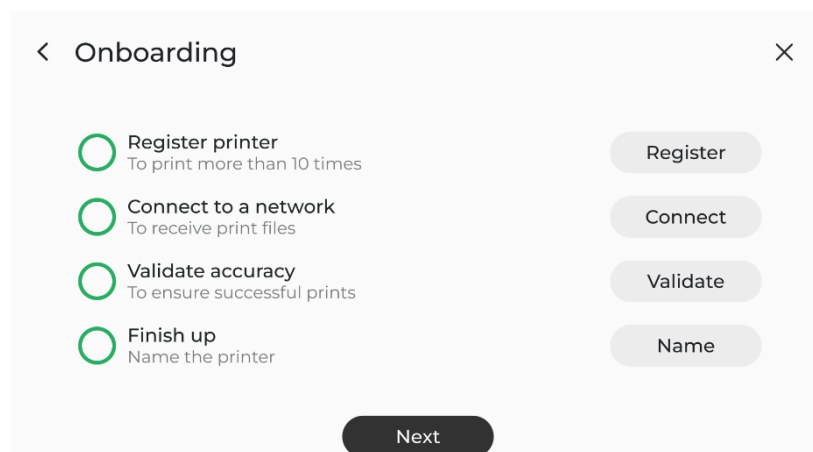

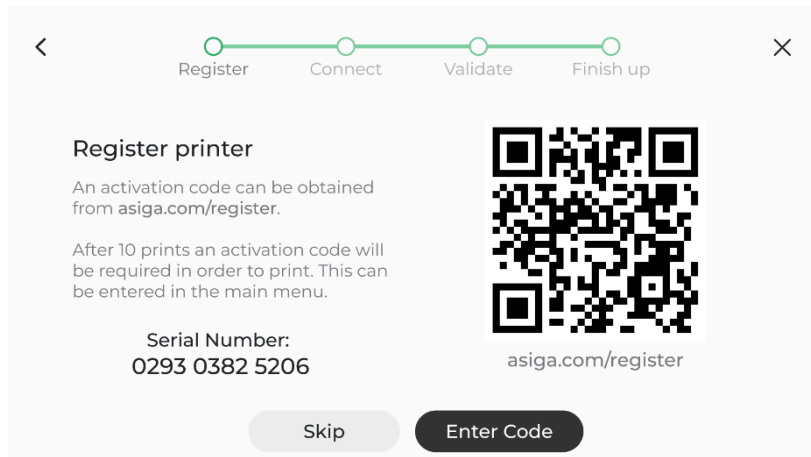

You can obtain your warranty code by visiting: www.asiga.com/register

You will be requested to register an account. Once your account has been activated, you will be directed to a screen where you can enter the serial number of your machine. The warranty code registers your machine with Asiga and commences the one-year warranty on your system. Alternatively, your reseller may provide you with the warranty code.

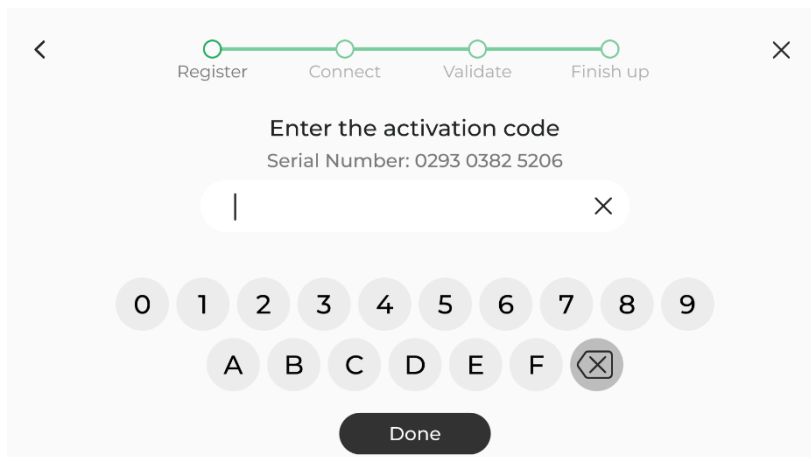

You can operate the MAX 2 without entering the warranty code. However, you can only complete a maximum of ten builds. After this the warranty code needs to be entered to continue printing with the MAX 2.

Connect to a network

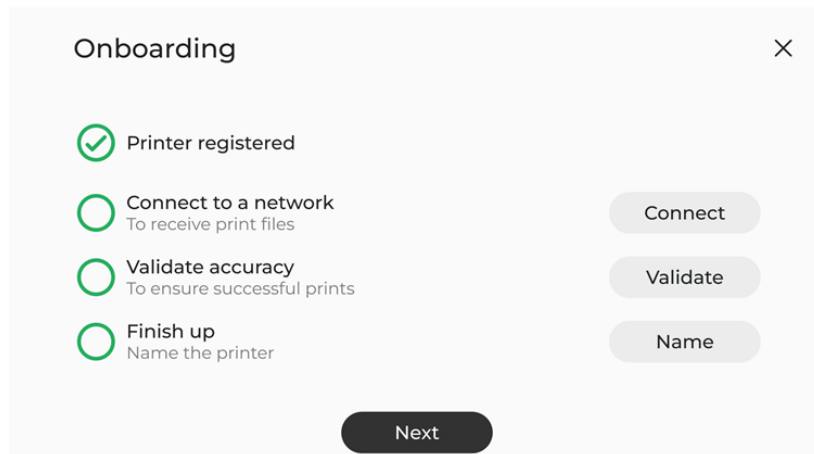

Select your preferred network method:

- Ethernet
- Wireless Direct
- Wireless

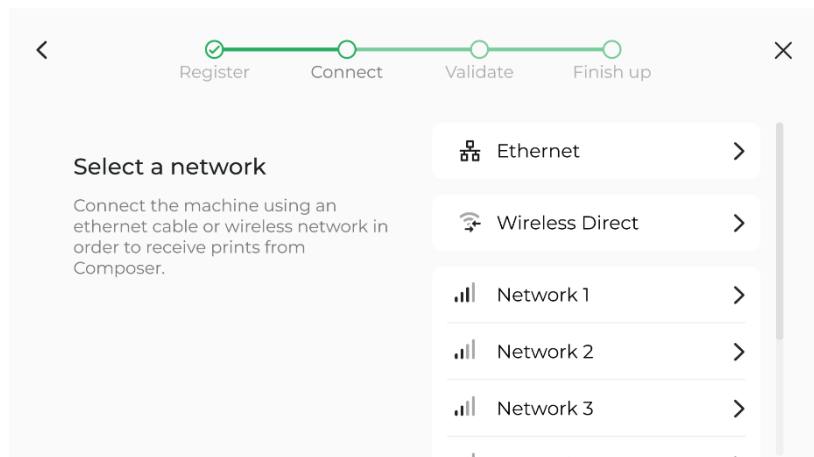

Platform Calibration

Note: a video demonstration of the zero position calibration procedure is included on the USB stick which ships with your machine.

Correct operation of the MAX 2 requires:

1. The build platform to be parallel to the glass window; and
2. The build platform to be in contact with the glass window when the vertical axis position is set to zero.

This is accomplished by performing the Platform calibration procedure.

The Platform calibration is done in the factory before the machine is shipped. However, it is recommended to recalibrate this position after the machine is transported or every few months. Poor Platform calibration can result in models not attaching to the build platform.

To calibrate the zero position:

1. Navigate to Settings > Hardware > Smart Positioning System (SPS) > Platform Calibration

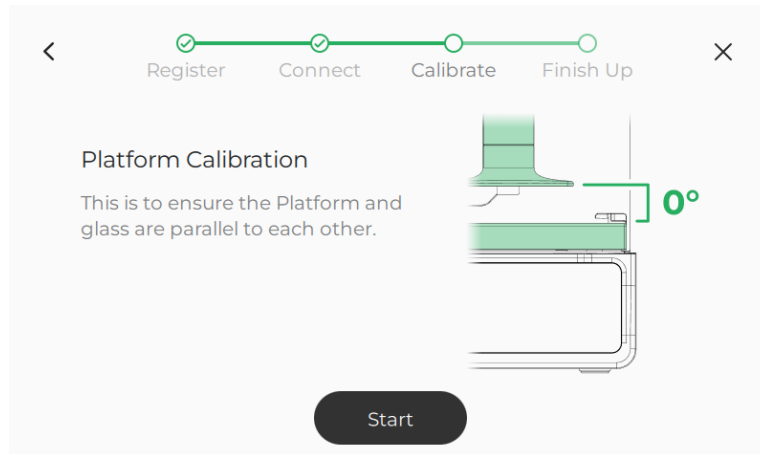

2. Install the build platform onto the vertical axis bracket

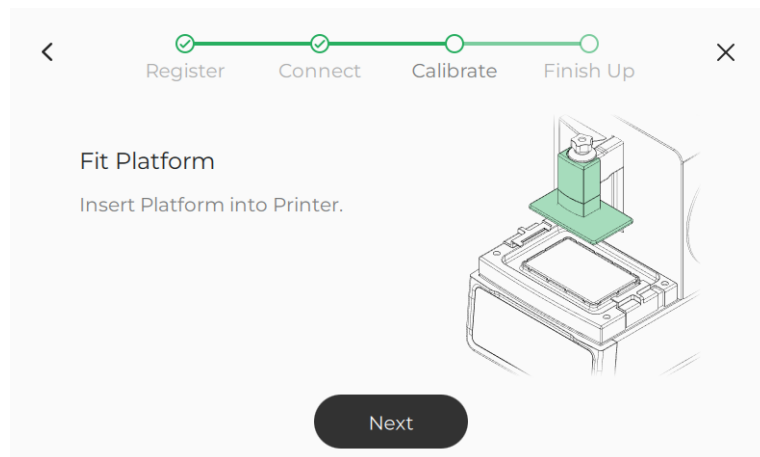

3. Tighten the Build Platform Release Knob to secure the build platform in place.

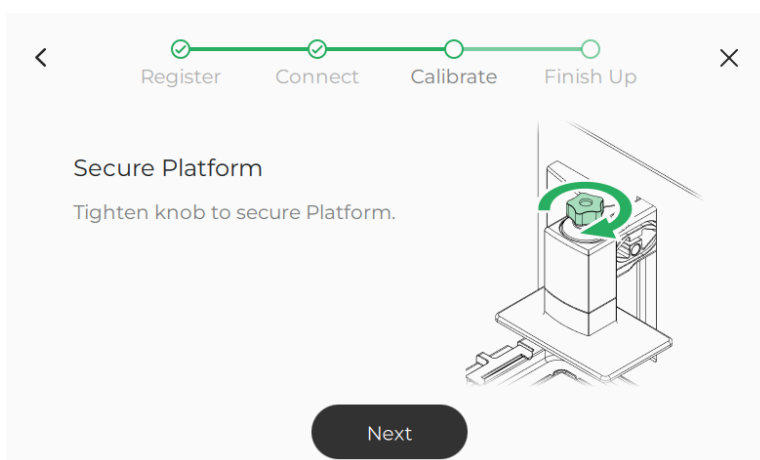

4. Loosen the Calibration Screw with a 4mm hex key hand tool, which is included in the MAX 2 Calibration Tool Kit. When the screw is properly loosened, the build platform should be able to move freely up and down and rotate around the horizontal axes of the machine.

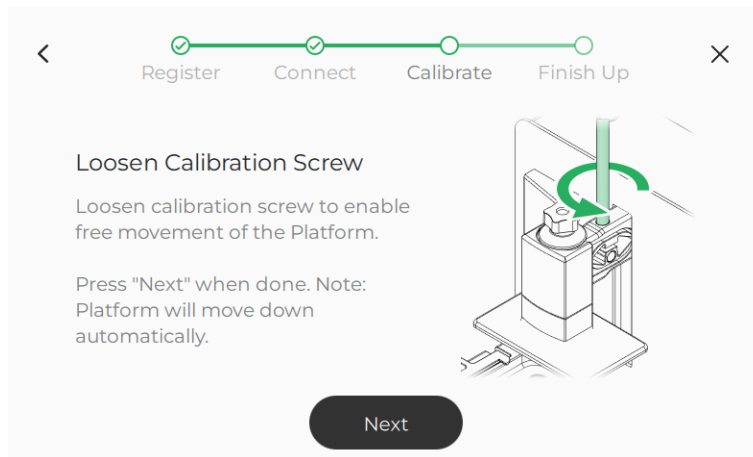

**The platform will automatically move.
Ensure there is no debris and keep hands clear of all moving parts!**

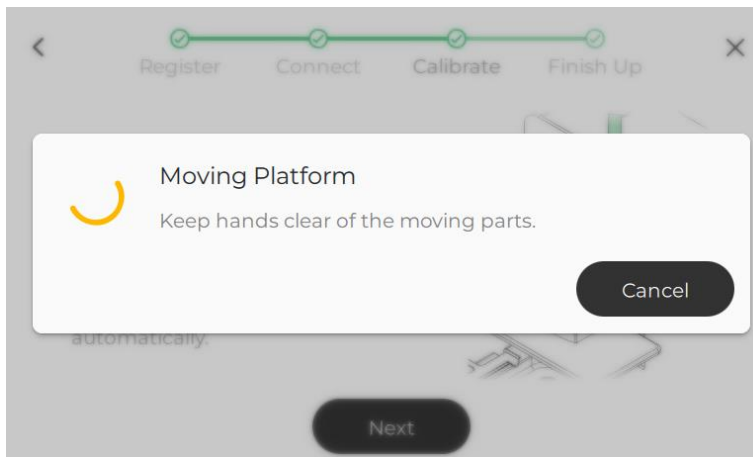

5. Tighten Calibration Screw

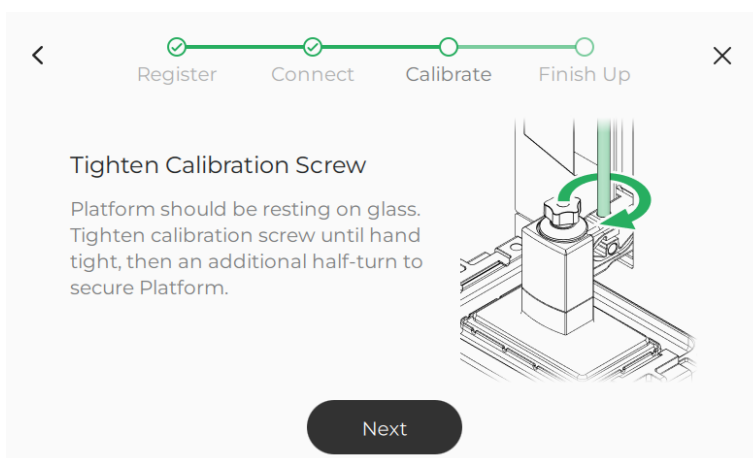

6. Detect the zero position. The feedback from the position encoders may be used to automatically detect the zero position of the build platform. To run the automatic detection process, click "Next"

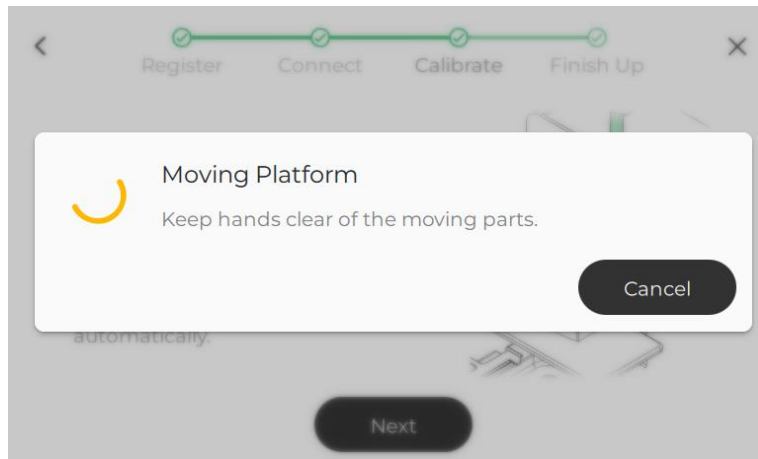

The platform will automatically move.
Ensure there is no debris and keep hands clear of all moving parts!

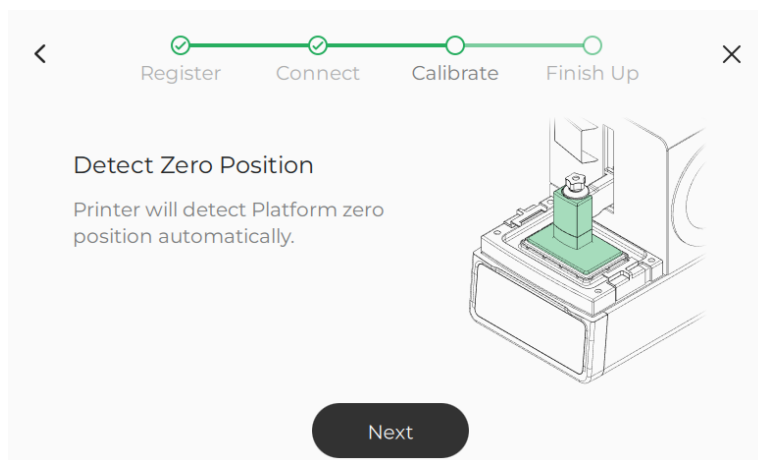

Pressing Cancel will stop the “detect zero position” process and skip to the “Home vertical axis?” screen.

7. Calibration Complete

After the process is completed, the Platform will home to the highest position.

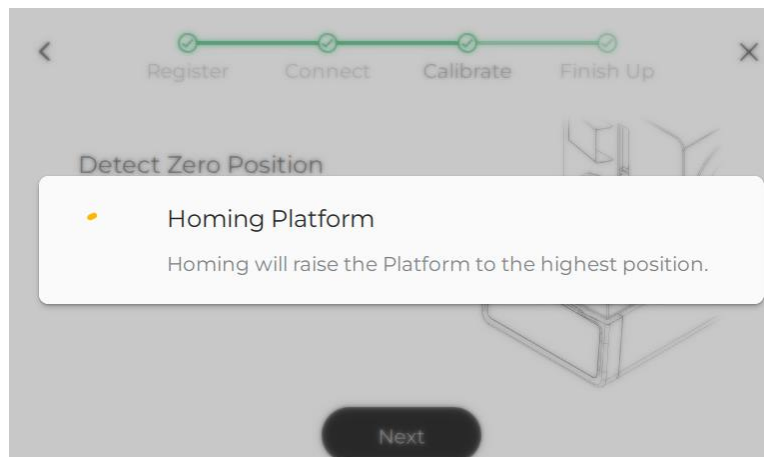

Press "Done" to complete the Calibration Process

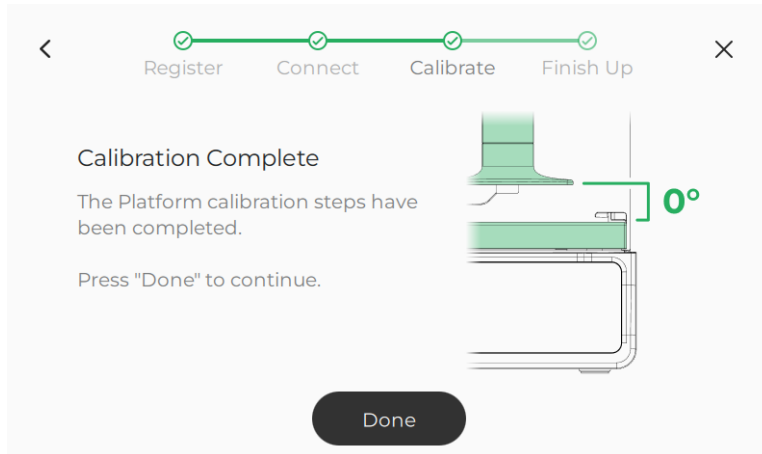

The onboarding process is complete

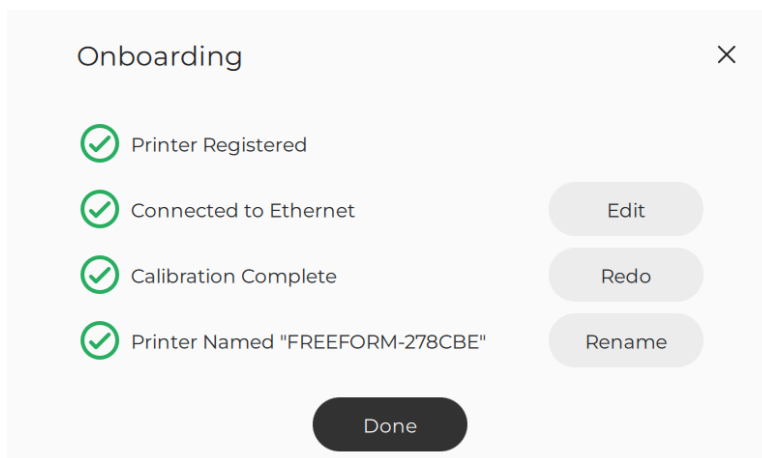

Zero Position Encoders

The MAX 2 is equipped with four position encoders built into the corners of the glass base-plate. The position encoders allow microscopic deflections in the mechanical structure to be measured during the formation of a model layer, allowing model layers to be formed with precision.

The position encoders should be zeroed after transporting the machine. The position encoders may drift so they should also be zeroed from time-to-time by the user. The procedure takes less than 30 seconds. The procedure for zeroing the position encoders is as follows:

1. Open the menu item Maintenance > Position Encoders.

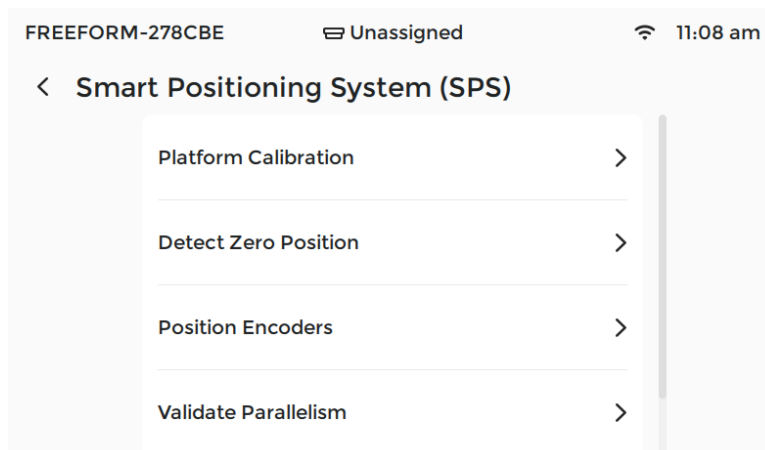

2. Press “Zero Position Encoders”.

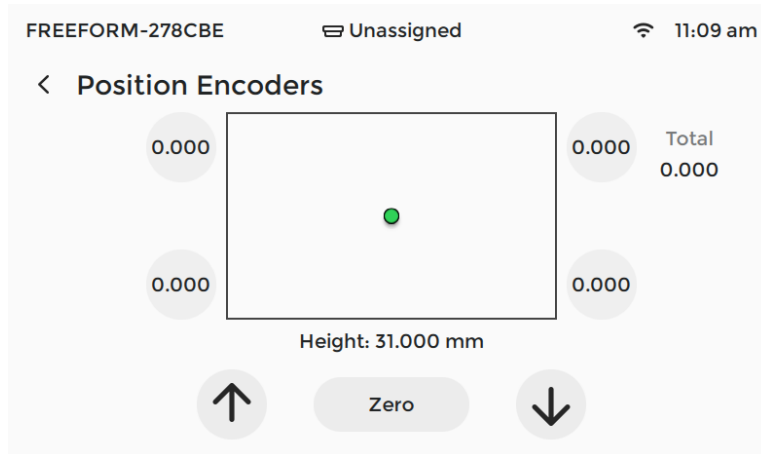

3. The empty square region shows a two-dimensional deflection map of the build envelope with a blue dot at the zero center. Pressing the up and down arrows will move the vertical axis up and down. The current height in mm above the zero position is shown between the arrows.
4. Pressing the “Zero” button will show the following prompt:

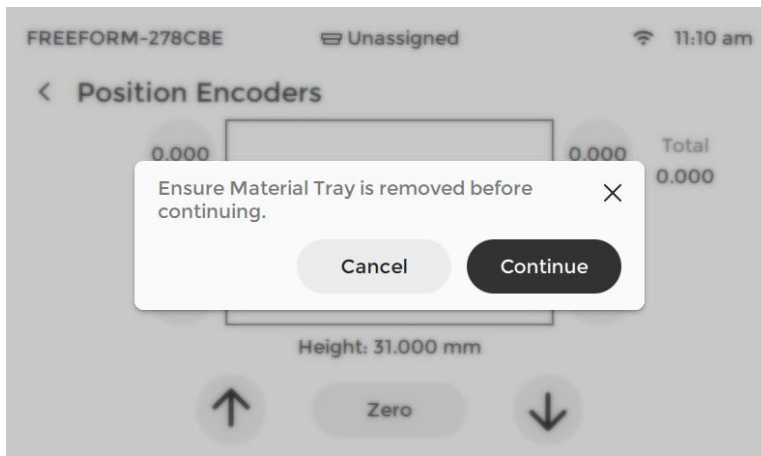

5. Remove the build tray from the machine. **There should be no objects in the build tray area or anything pressing on the machine.** The machine should be on a level surface in a low vibration area. Press “Cancel” to abort the process, otherwise, when ready, click “Continue” to record the zero position.

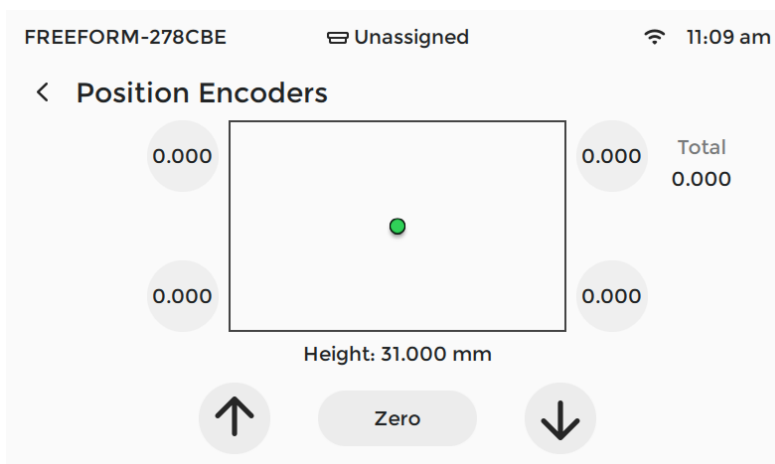

6. The process is complete. The green dot should be in the center of the square.

Network Connection

Build jobs for the MAX 2 are prepared on a personal computer and sent to the MAX 2 via a network connection. The MAX 2 has two networking options:

1. Ethernet 10/100 port on the rear of the machine
2. Wireless
3. Wireless Direct

Ethernet Setup

Plug one end of the included network cable (RJ45 connector at both ends) into the Ethernet port at the rear of your MAX 2 machine. Plug the other end into a hub/switch/router on the same network as your computer. Alternatively, if there is no network, you can plug it directly into your computer.

The default network setting is Automatic Configuration, which allows your network to automatically assign an IP address to the MAX 2 machine if there is a DHCP server present. If there is no DHCP server present, the MAX 2 will fall back to Automatic Private IP Addressing to assign an unused address in range 169.254.1.0-169.254.254.255 with a subnet mask of 255.255.0.0.

If you wish to assign a fixed IP address to the MAX 2 machine for Ethernet:

1. Go to Settings > General > Connectivity > Wired Network
2. Toggle off Automatic Configuration
3. Select IP Address, enter the IP address and select Save
4. Select Subnet Mask, enter the subnet mask and select Save
5. Setting the Gateway, Primary DNS and Secondary DNS is optional and may be left blank

Wireless Setup

1. Go to Settings > General > Connectivity > Wireless
2. Select Network Name
3. Select the desired wireless network from the list. Wireless networks that require a password will have a lock icon shown.
4. If required, enter the password and select Connect. The password will be remembered so that the printer can reconnect again if the wireless connection is interrupted, the printer is restarted or the printer is turned off and on.
5. A spinning circle animation will be shown while the printer is connecting to the network. If the printer has connected successfully, a tick icon will be shown.

If your wireless network does not have a DHCP server present, you may need to assign a fixed IP address as detailed in the Ethernet Setup section.

Wireless Direct Setup

Wireless Direct allows the printer to act as a wireless access point for connecting to the printer wirelessly. This may be useful if you do not have a wireless access pointer or router that the printer can connect to. Note that enabling Wireless Direct will prevent connecting to an existing wireless network using Wireless Setup.

1. Go to Settings > General > Connectivity > Wireless Direct
2. Toggle on Enabled

By default, the printer will create a wireless network with the name set to the printer's name and the password will be randomly generated. You can select Network Name or Password to change them.

The printer will have an IP address of 172.27.10.1 with subnet mask 255.255.255.0. It will also act as a DHCP server and assign IP addresses in the range 172.27.10.2-172.27.10.254 to wireless devices that connect to it. The IP address and subnet mask of the printer cannot be changed when using Wireless Direct.

Install Composer Software

Build jobs for the MAX 2 are prepared on a personal computer using Asiga Composer™ software. Asiga Composer™ software is provided on the USB stick included with your MAX 2 or can be downloaded from the Asiga website. Asiga Composer™ runs on Windows, Mac and Linux.

To install Composer:

1. Insert the USB stick into a USB port of your computer.
2. Browse to the folder “Composer Software”.
 - a. For Windows click “composer-XXXX-win32.exe” or “composer-XXXX-win64.exe” depending on whether your operating system is 32-bit or 64-bit respectively.
 - b. For Mac click “composer-XXXX-x86_64.dmg”.
 - c. For Linux click “composer-XXXX-i686.tar.xz” or “composer-XXXX-x86_64.tar.xz” depending on whether your operating system is 32-bit or 64-bit respectively.

Preparing a Build

Build jobs for the MAX 2 are prepared on a personal computer using Asiga Composer™ software. Refer to the Composer User Guide for more information.

CHAPTER 4 Starting a Build

Installing the Material Tray

1. Open the hood of the machine.
2. Insert the tray with the Material Tray sensor sticker located towards the back of the machine.
3. Pull the sliding latches towards the front of the machine to lock the tray in place



Add Resin to the Material Tray

The resin height in the vat should be sufficient to keep the bottom film covered with resin during the print. Approximately 10mm of resin depth is generally sufficient.

See 'MAX LEVEL' mark on Build Tray

Clean the Material Tray Bottom

Commencing a build when there is solid debris in the vat can cause damage to the vat film. Debris can result whenever:

1. A part has failed to print correctly.
2. A model breaks during fabrication.
3. Resin in the vat is exposed to light.

It is prudent to check the vat bottom for any solid debris before every print. Do this by wiping resin away from the bottom of the vat with a piece of cardboard (a business card is ideal). Any cured debris can be aggregated by blanket exposing the build envelope with UV light from the projector. The following procedure should be used:

1. Go to Tools > Clean Material Tray from the Main Menu and press the "Start" button on the LCD screen. This will expose the material for approximately 45 seconds.

Warning

UV light will be emitted. Avoid direct exposure of eyes and skin.
Close the machine hood, or wear the UV safety glasses at all times.

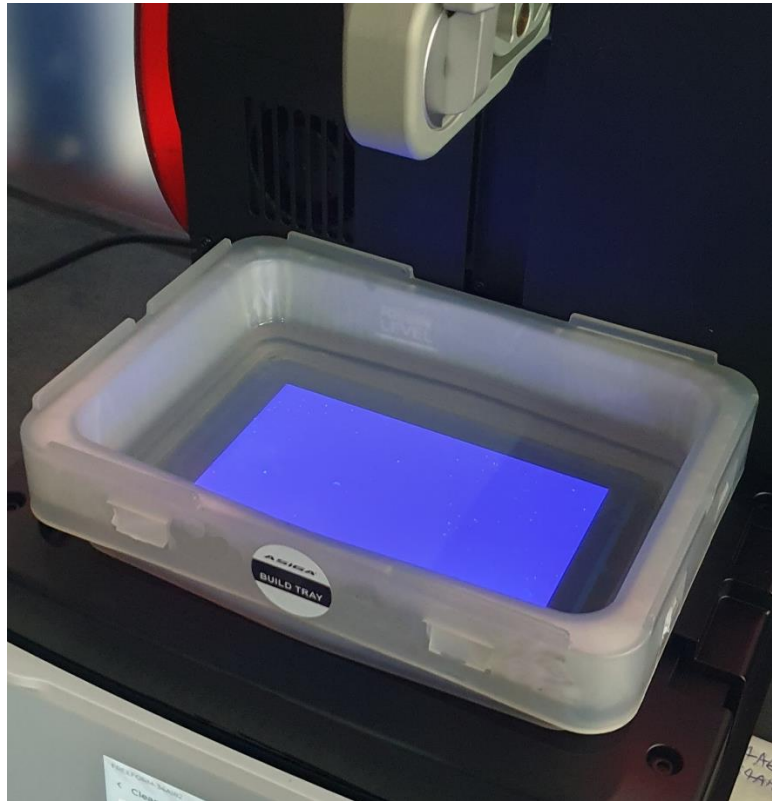

2. Remove the Material Tray from the machine. There will be a cured rectangle of material adhered to the vat bottom.

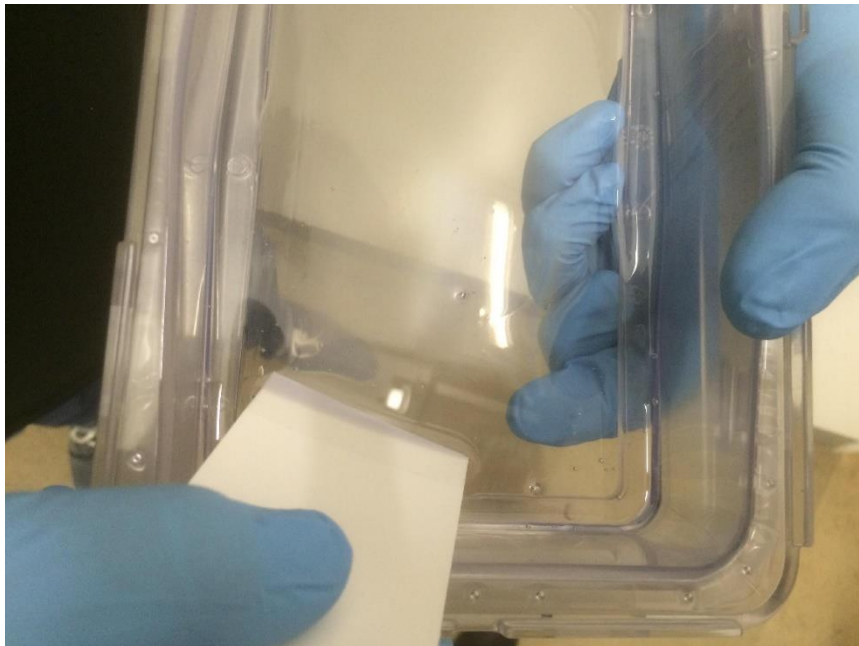

3. Place a finger on the underside of the Material Tray film at a corner of the cured rectangle. Your finger will provide support for the next step.
4. Use a piece of cardboard or plastic film to slide under the edge of the cured rectangle and lift it off the film.

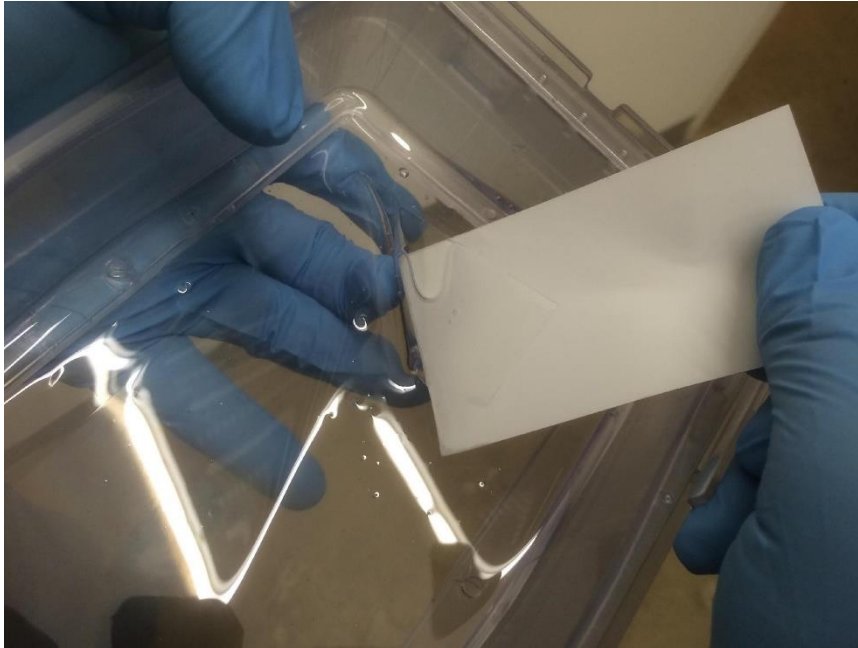

5. Remove the cured rectangle in one piece and dispose of it.

Set the Chamber Temperature

The MAX 2 is equipped with an internal temperature controller which regulates the temperature of the build chamber. Temperature control is useful when building with some materials to control their viscosity, reactivity and solidification.

The chamber temperature can be set for when:

1. The machine is idle (i.e. not building any parts)
2. The machine is building a part.

The idle chamber temperature settings are accessed via the menu **Settings > Hardware > heating**

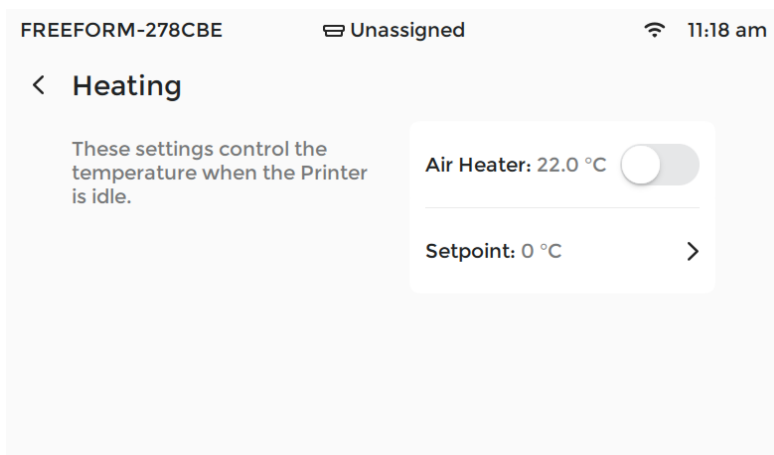

The Controller toggle allows the temperature controller to be activated or deactivated.

The Setpoint sub-menu allows the setpoint temperature to be entered.

The Thermometer field shows the current chamber temperature.

Note that the controller and setpoint settings under this menu are only employed while the machine is idle. Use this menu to control the temperature of the material while the machine is not building parts. When the machine is building a part, the build temperature setpoint set in the Asiga Composer Build Wizard is applied.

Starting the Build

Start the build on the MAX 2's home screen or Build Queue.

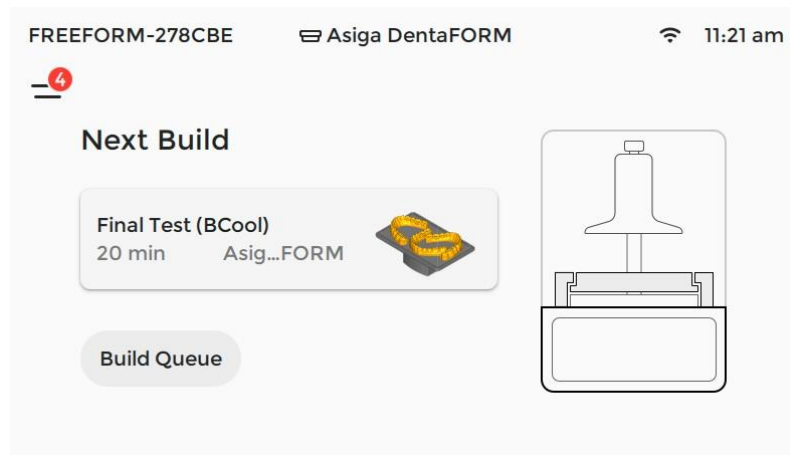

Note: The Menu Icon will display number of queued builds.

To start the Next Build, select it from the home screen.

To start another Build, select the 'Build Queue'

Next Build

Builds are displayed in chronological order on the MAX 2.

To start the Next Build, select it from the home screen.



The Preview screen displays relevant Build information.

To start, select 'Print'.

Build Queue

The Build Queue shows all currently queued Builds.
The first entry is the previous Build.

The next entries are queued in chronological order.

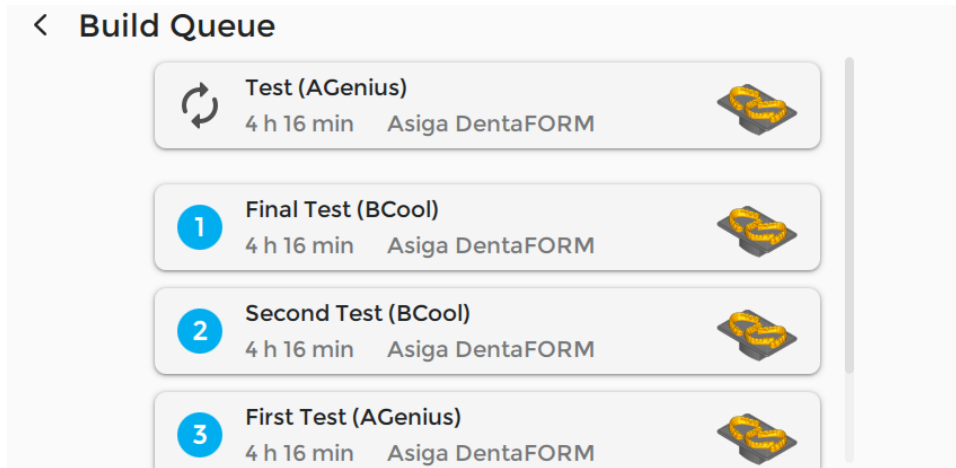

Select the desired Build to continue.

Build checklist

The MAX 2 will run through a pre-inspection checklist.

The machine will confirm the following settings:

- Correct Material Tray fitted
- Hood state: open/closed
- Heaters enabled/disabled. *

*Note: This can be skipped at any time.

When the pre-inspection is complete, the print will start automatically.

Build screen

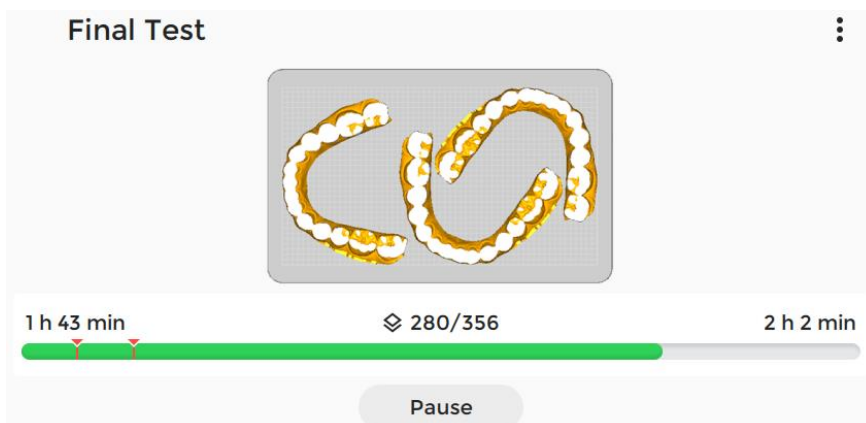

The following items are shown on the build screen by default.

Job name	Current layer
Layer preview image	Total layers
Time elapsed	Skipped layers
Estimated time remaining	

Optional settings include: Auto-shutdown and Diagnostic Data (SPS)

Auto-shutdown

Auto-shutdown will shut down the machine after printing is complete. This can be engaged in two different ways.

One-time event

To enable auto-shutdown once, select the 'more' icon (three dots) in the top right section of the Build screen.

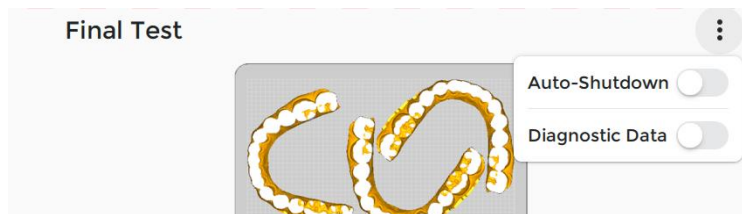

Slide the icon to 'Engaged'.

Permanent auto-shutdown

Auto shutdown can be enabled as default behaviour in the menu. Go to Settings > Power and select "Always shutdown after printing"

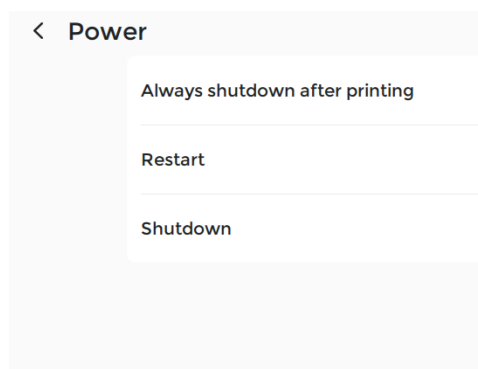

Diagnostic Data

Diagnostic data will display printer telemetry such as chamber temperature, SPS data, IR lamp heaters etc. This can be used for troubleshooting.

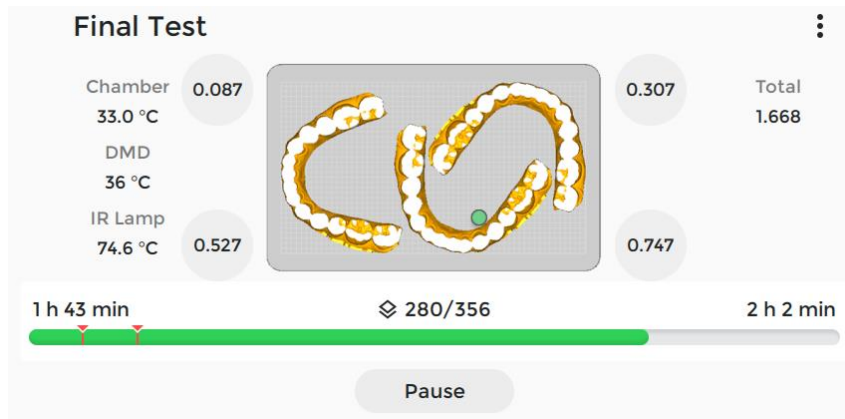

Stopping and Pausing the Build

A build can be paused by pressing the pause button

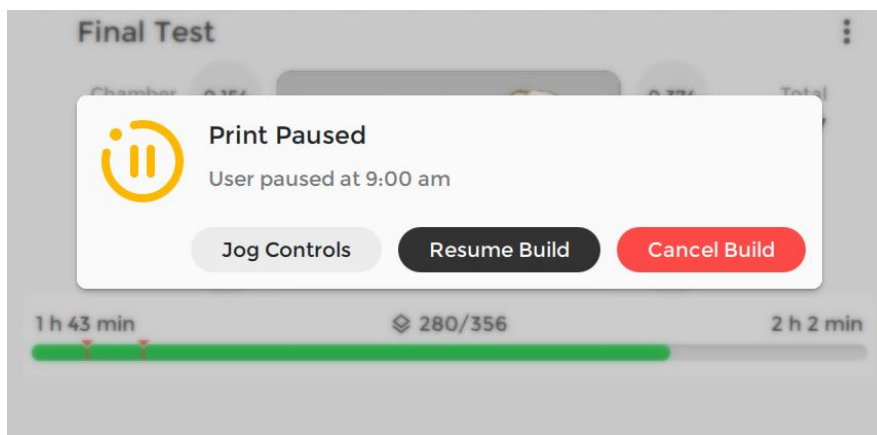

When the build is paused you can raise or lower the build using the jog controls. You can continue the build with the Resume button or abort the build with the Cancel button.

Canceled builds can be continued with the **Build Queue** menu item.

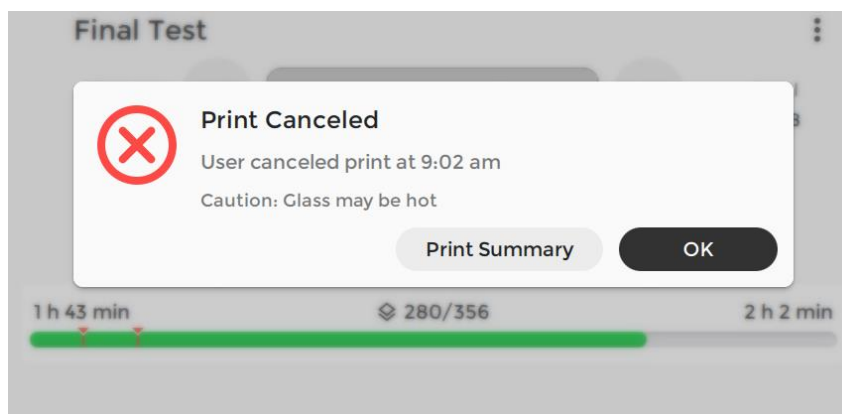

CHAPTER 5 **Web Interface**

The MAX 2 runs an internal web server which is visible to web browsers on the same network. This Web Interface presents important control screens for interacting with the MAX 2.

Accessing the Web Interface

There are two ways of accessing the web interface:

1. Click on the “Web Interface” button in the Composer toolbar.

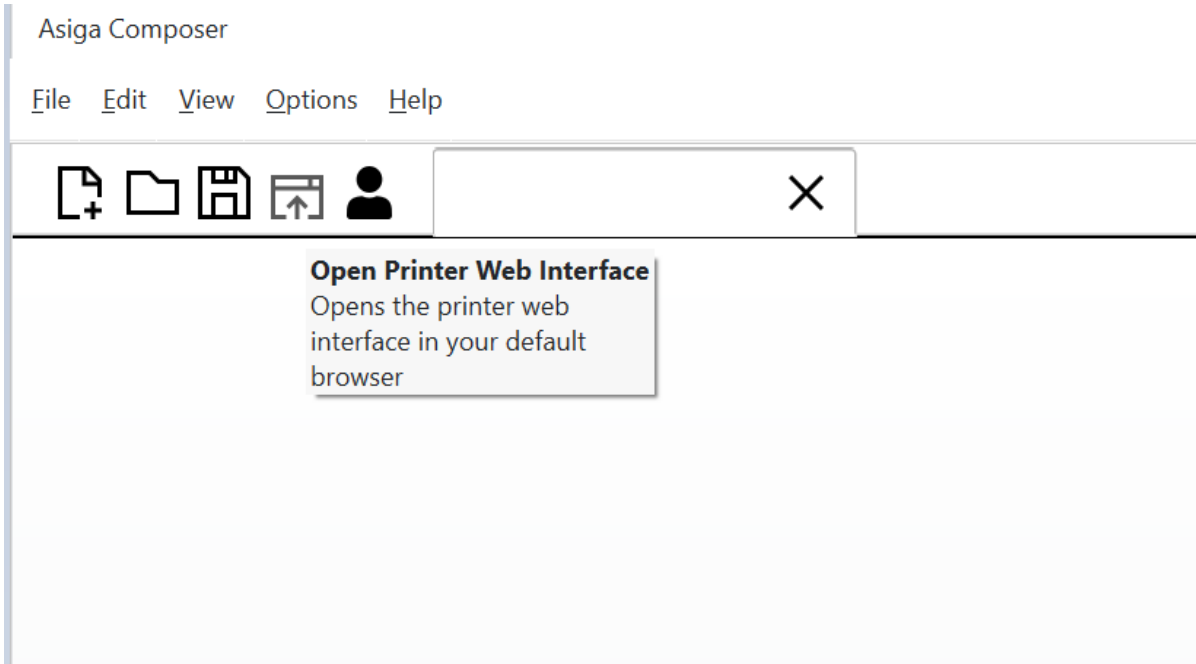

2. Open a web browser and type into the navigation bar “http://” followed by either the name of your printer or the IP address or printer, e.g.:
 - a. `http://FREEFORM-D06D10`
 - b. `http://192.168.1.53`
3. Press Enter.

There are 6 tabs in the Web Interface: Build Queue, Front Panel, Settings, System Information, Update Firmware and Support.

Build Queue Tab

The build queue allows you to view information about the current build and queued builds.

The Current Build field shows the last build that was started. Selecting Print > Repeat Build will run this job again.

ASIGA
Max 2

Build Queue Front Panel Settings System Information Update Firmware Support

Max 2 (eng-ml-16)

Build Queue

To manage your build queue use the up/down arrows or simply drag & drop.
Click the "info" icon to view information on the build.

Current Build

Build Name	Build Time	Computer	Username	Added
 eight	1 min 23 s	solstice1	jliu6683	2024-02-15 05:52:01 PM

Queued Builds

Order	Build Name	Build Time	Computer	Username	Added	Delete
▼▲	 kk	1 min 23 s	solstice1	jliu6683	2024-02-15 07:02:41 PM	✘

Copyright © 2024 Asiga. All rights reserved.
[License Terms](#)

The Queued Builds list shows the list of jobs that have been submitted to the printer in order of receipt. Selecting Print > Next Build from the front panel will print the first build in the Queued Builds list. Selecting Print > Select Build from the front panel will allow you to choose any builds from the queued builds list.

Further columns indicate data about the builds:

Build Time – Estimated time for printing

Computer – Name of the computer that uploaded the build

Username – Name of the user that uploaded the build

Added – Date/time the build was uploaded

Queued builds may be reordered by clicking the up/down arrows ▼▲ next to the build name or by dragging and dropping. A build can be deleted by clicking the Delete icon ✘.

You can click the information icon  next to a build to view additional information about the build in a popup window. The following information is available:

Parts List – List of parts in the build and their dimensions

Thumbnail – A screen capture of the 3D view in Composer at the time the build wizard was started. You can click on this thumbnail image or the "Show Full-Size Image" link to show the full size image.

Download Build – Downloads a ZIP file containing the build parameters and the images displayed by the projector during exposure.

View Build Parameters – Shows the build parameters used for printing such as material name, temperature setpoint, burn-in range, separation velocity/distance, approach velocity, exposure times, etc.

Print View – Print the information shown in the window (build time, computer, username, added, parts list and thumbnail)

Front Panel Tab

The Front Panel tab allows you to see and remotely interact with the printer's touch screen from a web browser running on your computer, tablet or phone. You can interact with the front panel by pressing, releasing and dragging with a mouse on the touch screen image.

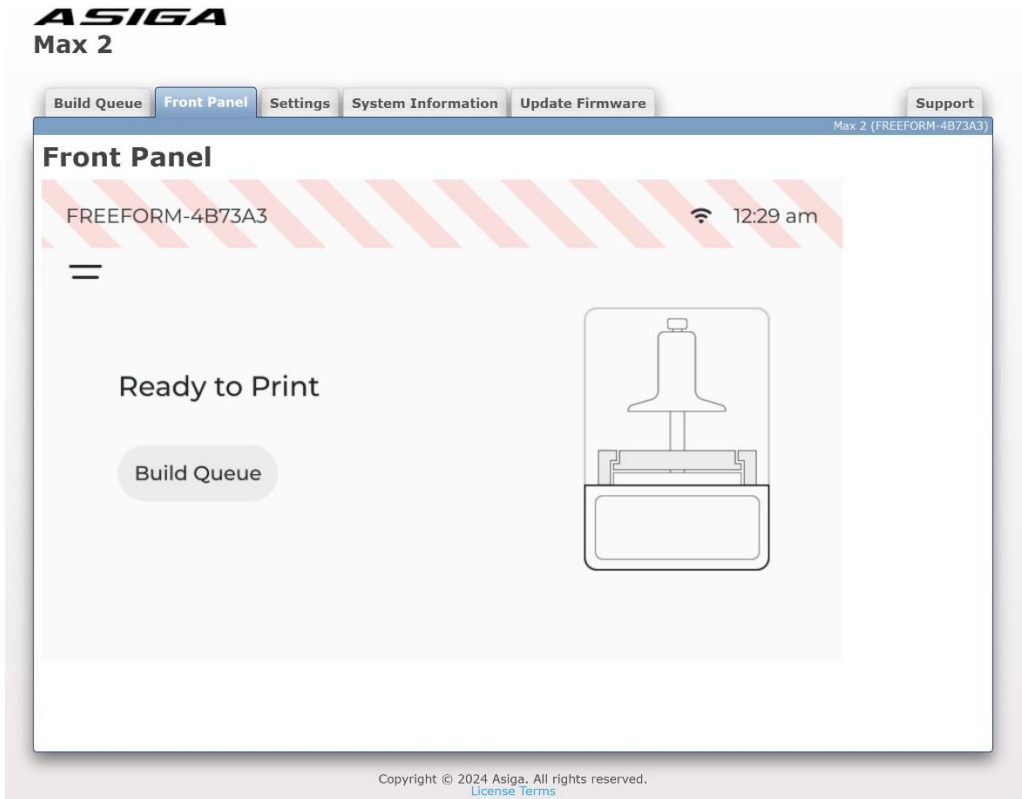

Settings Tab

The Settings tab is used to define the physical build extents and protection options of the MAX 2 machine.

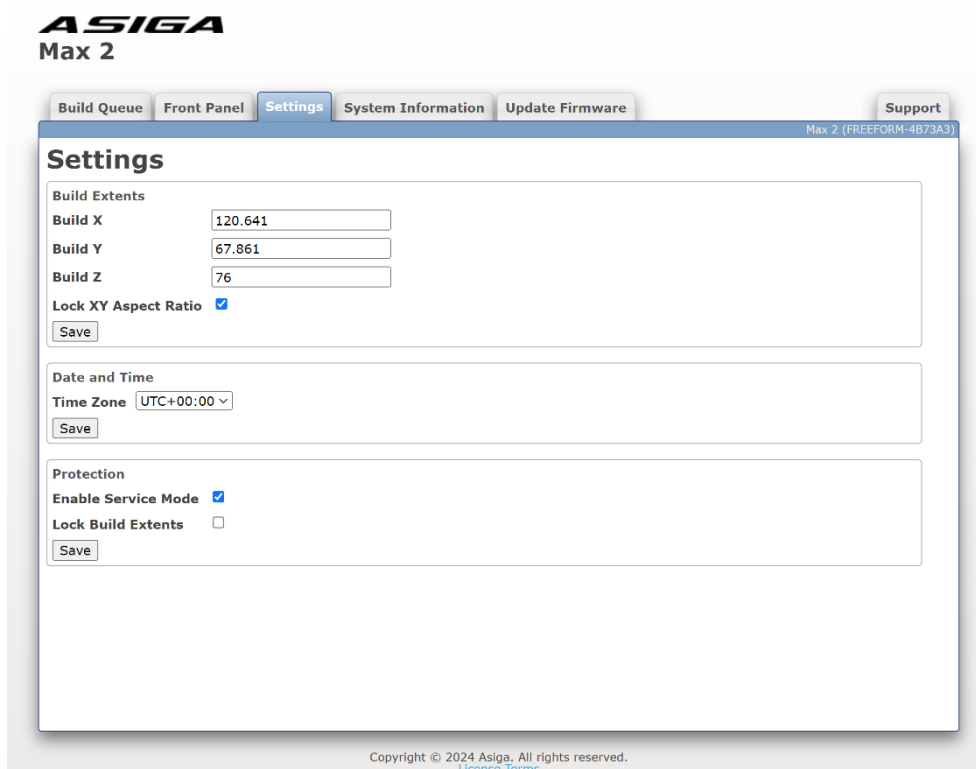

Build Extents

Build X – Width of the projected image (mm)

Build Y – Height of the projected image (mm)

Build Z – Depth of the build volume (mm)

Lock XY Aspect Ratio – Ticking this box locks the aspect ratio of the projected image to that of the imaging chip. It forces the pixels to be square.

The values “Build X” and “Build Y” must be determined by experimentation. This is typically done by building an object or objects which span the build volume and measuring the actual span in the X and Y direction. A suitable build may be one which included a cube in each corner of the build volume, commonly known as a “four cubes” build. The setup in composer for such as print is as follows:

The measured X and Y span values are entered into the appropriate fields and the “Save” button is clicked to save the changes.

Note that if the “Lock XY Aspect Ratio” box is ticked the entered value for Build X will automatically update the Build Y value and vice versa. This allows the calibration technician to recheck measurements and possibly correct any keystone error in the projected image. If the “Lock XY Aspect Ratio” box is unchecked, any values can be entered for the Build X and Build Y and a square pixel is not guaranteed. Re-checking the “Lock XY Aspect Ratio” box will recalculate either Build X or Build Y to minimize the change to either value.

Note that the Build Z span is defined by the travel of the vertical axis minus the allowed separation distance.

Protection

Hide Service Menu – Ticking this box hides the Maintenance > Service menu from the Front Panel.

Lock Build Extents – Ticking this box disables the Save button for the Build Extents, preventing changes to Build X, Y and Z.

System Information Tab

The System Information tab shows useful information about the printer.

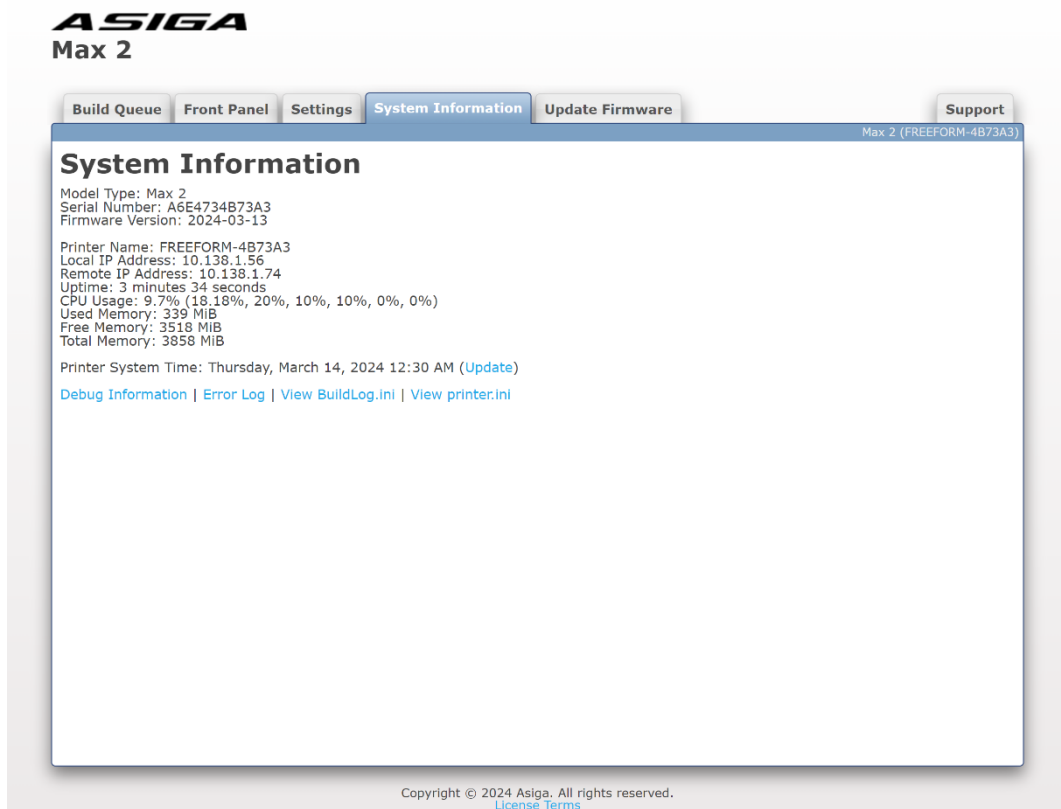

Model Type – This will be “MAX 2” for a MAX 2 printer

Serial Number – This will be 12 hexadecimal characters (0-9, A-F). The MAC address of the wired Ethernet interface of the printer will be the same as the serial number. (e.g. a serial number of 0123456789AB corresponds to a MAC address of 01:23:45:67:89:AB).

Firmware Version – This will be the date the firmware was created (e.g. 2015-07-14) in the format YYYY-MM-DD

Printer Name – The name of the printer as visible in Composer's New Build dialog and on Windows networks. By default it is set to FREEFORM-XXXXXX where XXXXXX is the last 6 characters of the serial number.

Local IP Address – The IP address of the printer whose web interface you are accessing

Remote IP Address – The IP address of the computer where the web browser is running

Uptime – The amount of time the printer has been running

CPU Usage – Estimate of the percentage of the printer's CPU utilized. A combined usage and a usage for each CPU core is shown.

Used Memory – Amount of printer's RAM currently in use

Free Memory – Amount of printer's RAM remaining

Total Memory – Amount of printer's RAM installed

Printer System Time – Current date/time on the printer. The printer's clock runs in Coordinated Universal Time (UTC). For display purposes, a time zone offset can be set in Settings > Time Zone to show the clock in your desired time zone. Clicking the Update link will synchronize the printer's UTC date/time with the UTC date/time on your computer.

Debug Information – Shows a log of diagnostic messages since the printer was turned on (including error messages). The address bar of your web browser will show a URL ending in /debug. You can customize the behavior by adding some parameters to the end of the URL:

- /debug?n=100 will show only the last 100 lines
- /debug?n=20&f=1 will show only the last 20 lines and show additional lines added in realtime. Note that many web browsers will stop showing additional lines if there is no new lines after a certain amount of time. If you are using Firefox you can enter "about:config" into the address bar and change the network.http.response.timeout preference from 300 to 0 so it doesn't stop monitoring if there are no new lines after 5 minutes (300 seconds).

Error Log – Shows a log of error messages since the printer was turned on. The address bar of your web browser will show a URL ending in /errorlog. You can customize the behavior by adding some parameters to the end of the URL:

- /errorlog?n=100 will show only the last 100 lines

View BuildLog.ini – Shows a log of builds started/canceled and information about each build

View printer.ini – Shows the printer's current configuration

Update Firmware Tab

The Update Firmware tab allows you to upload a new firmware file onto the printer.

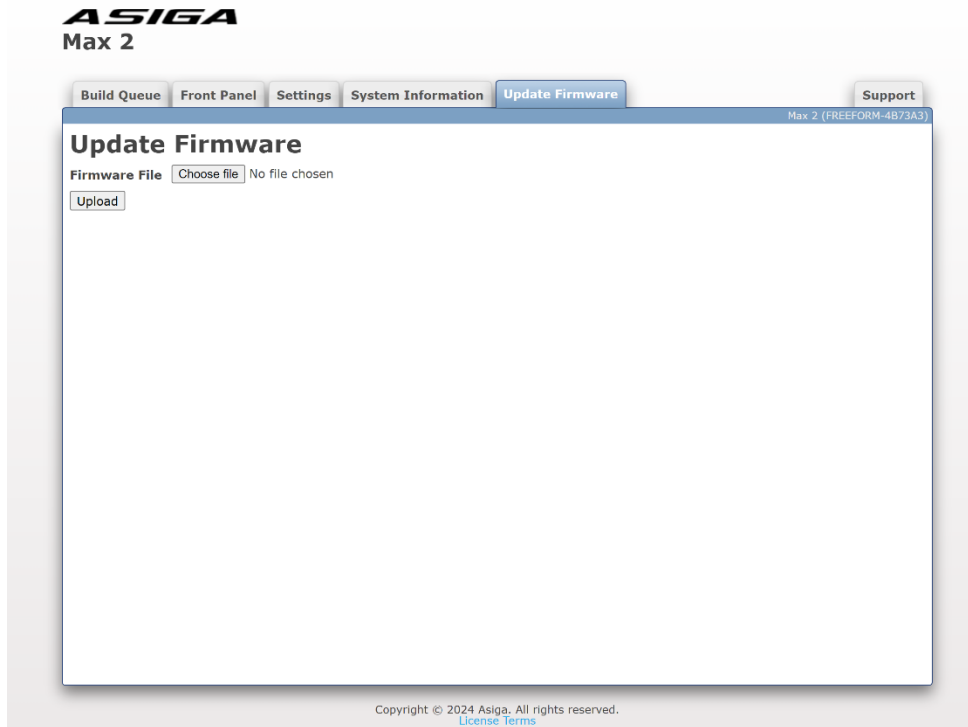

Firmware files have the file extension “.fw”. You can click Browse to select a firmware file and then click Upload to upload it. The printer will verify the firmware is valid and if it is, it will be added to the list of firmware in the System > Firmware Version menu on the front panel. You can then select the desired firmware from the Firmware Version menu to update to the selected version. The printer will keep the 5 most recently uploaded firmware files.

Support Tab

The Support tab provides contact details for obtaining support from Asiga for the printer and also provides an option to change the language of the web interface.

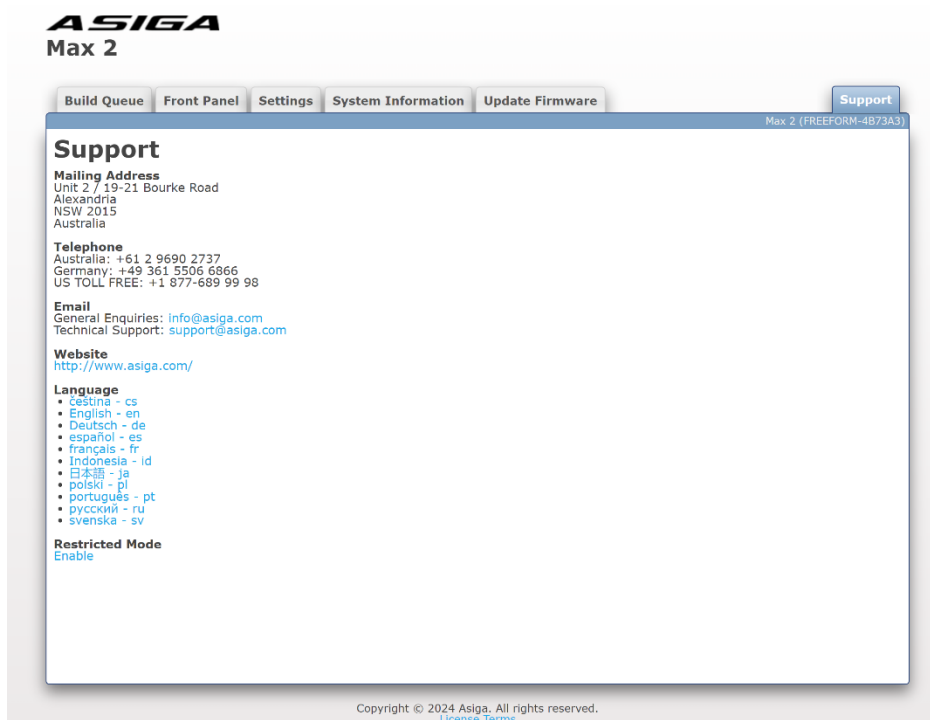

The selected language is stored in a cookie in the web browser. If no language has been selected or the web browser cookie is not present, the web browser's default language will be used if available.

The support tab also allows you to enable or disable Restricted Mode.

Restricted Mode

Restricted Mode allows you to set a password to make the Front Panel tab read-only, hide the Settings tab and disable updating the Printer system Time. This may be useful to lock down the printer to prevent users from modifying critical settings.

Restricted Mode Enable

Clicking the Enable link will pop-up a dialog prompting you to set a password by typing it twice and clicking OK. If the passwords don't match, the OK button will not be disabled and you will not be able to continue.



A dialog box titled "Set Password" with a close button (X) in the top right corner. It contains two input fields: "New Password" and "Confirm Password". Below the input fields are two buttons: "OK" and "Cancel".

After clicking OK, the Enable link changed to Disable.

Restricted Mode Disable

Clicking on the Disable link will prompt for the password. You can proceed with disabling Restricted Mode by either entering the password you set to enable Restricted Mode or entering the activation code from www.asiga.com/register that was used to register the printer (in case the password was forgotten).

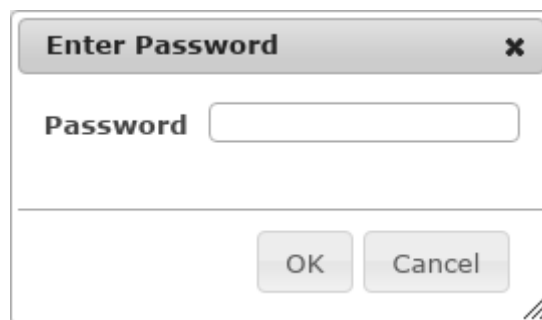

A dialog box titled "Enter Password" with a close button (X) in the top right corner. It contains one input field labeled "Password". Below the input field are two buttons: "OK" and "Cancel".

Policy Editor

The Front Panel of the printer can be locked down using the policy editor. By default, no policy is configured so all menu items are accessible as normal. The policy editor can be accessed by clicking opening the Build Queue tab of the web interface and then replacing /queue in the web address with /policy.

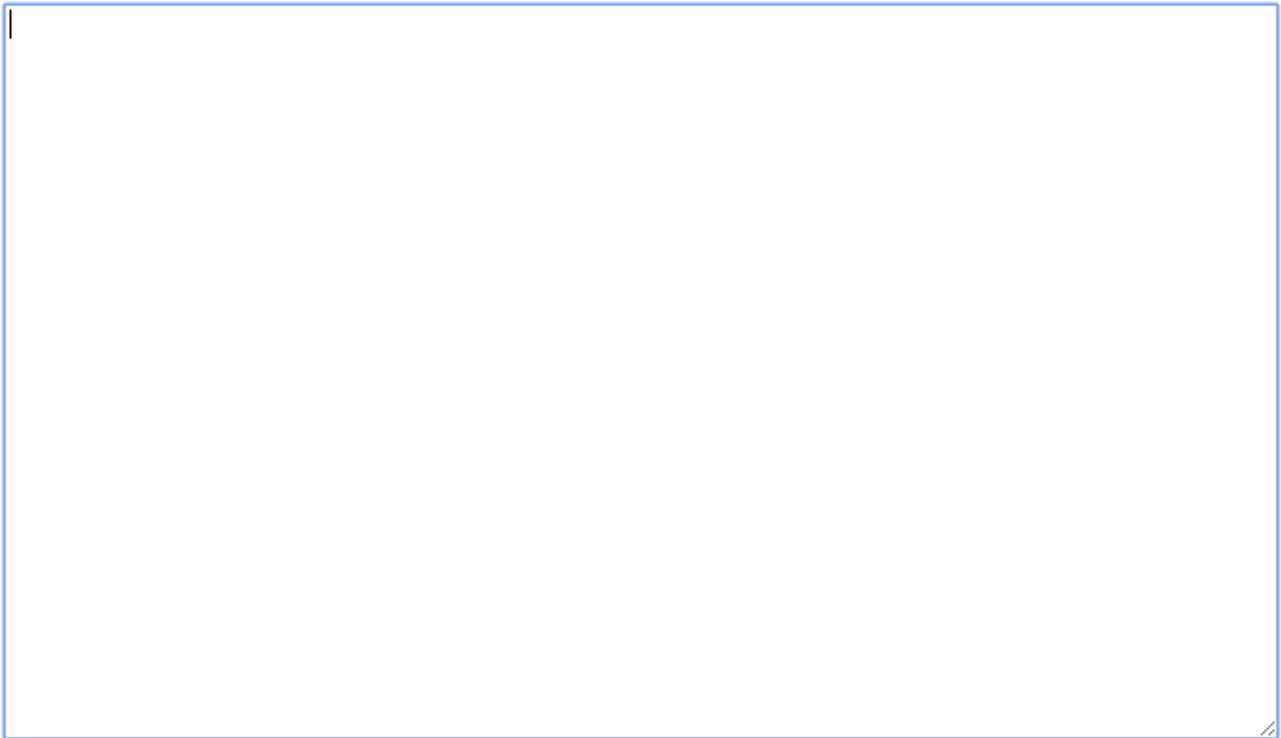

Save

The policy can be typed into the text box and applied by clicking Save. It will be applied immediately. If a text box and Save button is not shown, you need to disable Restricted Mode.

Here is an example policy that can be copy and pasted into the text box:

```
; Policy for Front Panel
```

```
:[Policy]
```

```
; This setting can be set to FALSE to disable the entire policy instead of clearing the policy
Enabled="TRUE"
```

```
[Front Panel]
```

```
; Hide the Restart menu item
```

```
Restart/Visible="FALSE"
```

```
; Disable toggling the Hood sensor
```

```
Maintenance/Sensors/Hood/Enabled="FALSE"
```

```
; Disable changing the printer name and time zone
```

```
Settings/Printer Name/Enabled="FALSE"
```

```
Settings/Time Zone/Enabled="FALSE"
```

```
; Hide the language
```

```
Settings/Language/Visible="FALSE"
```

```
; Comment lines start with a semi-colon and can contain any text
```

```
; Additional comments
```

```
; More comments
```

Lines starting with a semi-colon are comments that are ignored and can be located anywhere in the policy. You can add/remove them as desired.

You can add/remove lines from the [Front Panel] section of the example policy to do further customization.

Lines are of the format Path/Option=Value.

- Path – the path to menu item. This can be found by setting the language to “American English” and then noting down the names of the menu items you need to press to get to the item. For example to get to Time Zone you need to press “Settings”, followed by “Time Zone”. You join them together with the “/” character to get “Settings/Time Zone” which is the path. If the menu item has a colon, everything from the colon onward is excluded when forming the path (e.g. the path for “Settings/Language: American English” is “Settings/Language”).
- Option – this can be either “Enabled” or “Visible”
 - Enabled – controls whether the menu item can be pressed or modified
 - Visible – controls whether the menu item is visible
- Value – this can be either “TRUE” or “FALSE” (be double to include the double quotes when entering it into the policy)

CHAPTER 6 **Post-processing Parts**

Parts build on the MAX 2 need to be removed from the build platform, washed and post-cured.

Removing Parts from the Build Platform

Use a metal scraper or razor blade to remove parts from the build platform.

Washing Parts

Resin residue remaining on printed parts can be removed by washing in isopropanol. Best practice for efficient use of isopropanol is to maintain two baths: a “dirty bath” and a “clean bath”.

First wash the parts in the dirty bath. This removes the majority of the resin residue.

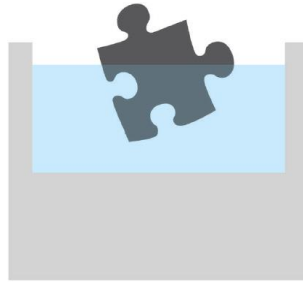

Then move the parts to the clean bath. This removes the remainder of the resin residue.

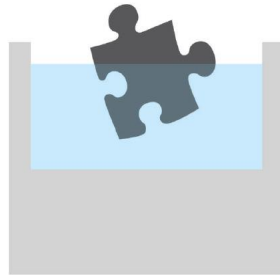

After the clean bath has been used for some time the resin can be transferred to the dirty bath and fresh isopropanol added to the clean bath.



Post-Curing Parts

Parts printed on the MAX 2 will not be fully cured and will consequently lack their full strength. Full strength is attained when the parts are fully cured. Asiga recommends using Asiga Cure, which is a UV light based post curing system for measurable delivery of optical dose, temperature and vacuum – significantly reducing user time and delivering repeatable and consistent results.



Asiga Cure comes in two sizes, 1.5L and 2.5L, has oxygen free curing, immersive 360 LED curing, Intelligent Dose Curing, Chamber heating to 80°C and Nitrogen Connectivity.

Your computer will connect to Cure and Composer will automatically upload builds and cure programs.

A Max 2violet Flash unit is included with your MAX 2. The Flash unit will be either 110V AC or 220V AC depending on your region. **CHECK THE VOLTAGE REQUIREMENTS OF YOUR FLASH UNIT BEFORE USE AND VERIFY YOU ARE CONNECTING THE CORRECT VOLTAGE.**

Turn on the UV unit and place the parts inside the chamber. Full strength is usually obtained in between 5 and 30 minutes.



The parts may still be tacky on the surface due to atmospheric oxygen inhibiting the photo-curing reaction. Full surface cure can be obtained by immersing the parts in a liquid to displace the oxygen and irradiating the immersed parts. Suitable liquids include oil, water and glycerol.

CHAPTER 7 Maintenance and Calibration

The Maintenance screen provides options for performing calibration and maintenance of your MAX 2 system.

Service Mode

Service Mode shows all calibration and maintenance settings. By default items such as projector calibration are hidden from users.

The MAX 2 will indicate being in Service Mode by showing a red/white banner in the Status bar.

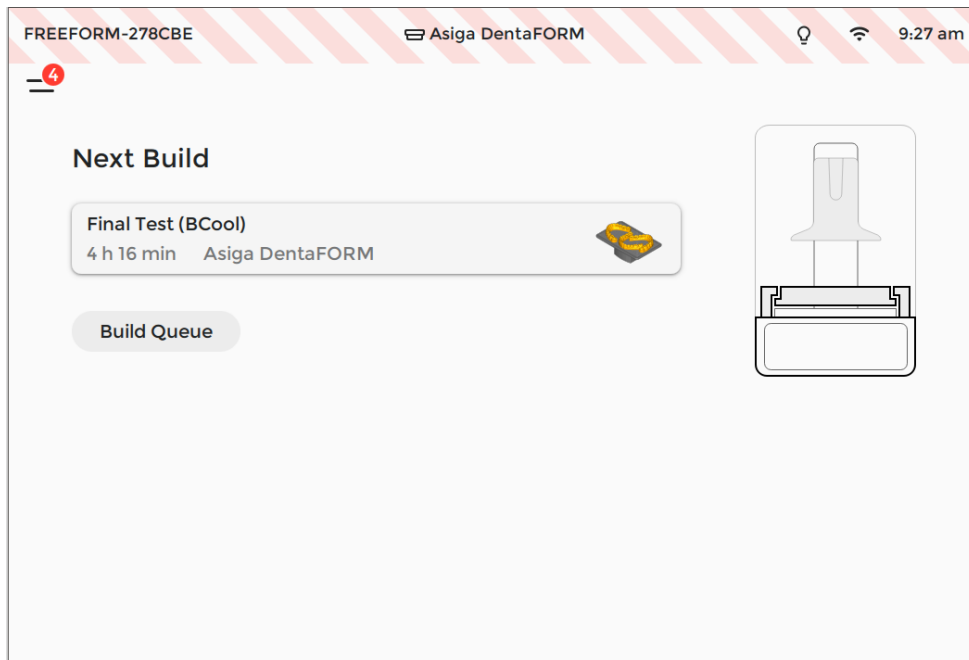

Service Mode will be automatically disabled when the machine is shutdown or restarted.

Enabling Service Mode is completed through the web interface.

To enable Service Mode, select the option in the web interface of your printer. Go to Settings > Protection > Enable Service Mode.

Zero Position

Please refer to the section on Zero Position Calibration in Platform Calibration (see Page 43)

Projector

The menu item Settings > Hardware > Projector shows settings for adjusting the LED.

1. **Radiometer:** Reading the internal radiometer value for the LED power.
2. **Power Level:** Sets the Power Level of the LED.

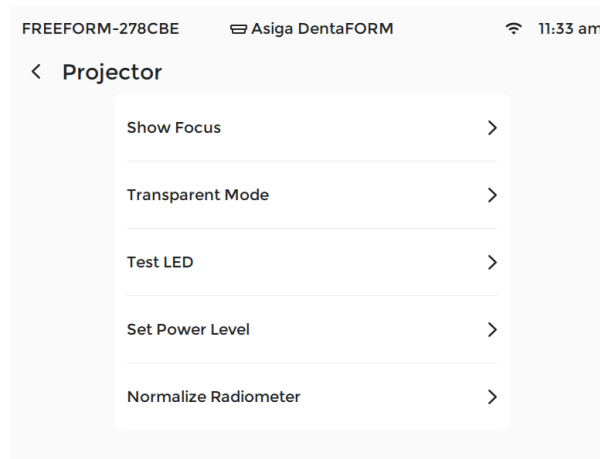

Sensors

The MAX 2 Sensors screen is reached in the menu Settings > Hardware > Sensors. The Sensors screen shows toggles for the Hood, LED and Material Level.

When the hood sensor is activated, jobs will not build if the hood is open. This can be disabled by deactivating the hood sensor.

LED intensity is checked every build layer. The build will halt if the LED intensity drops more than 50% below the starting intensity. This feature can be disabled by disabling the LED sensor.

The material level is checked every build layer. The material weight is calculated by subtracting the tray weight from the total weight above the bund and then checked against a minimum weight. If the material weight is less than the minimum weight, the build will be paused and the message “Material level is too low” will be displayed. This gives the user the chance to add more build material or cancel the build. This feature can be disabled by deactivating the Material Level sensor.

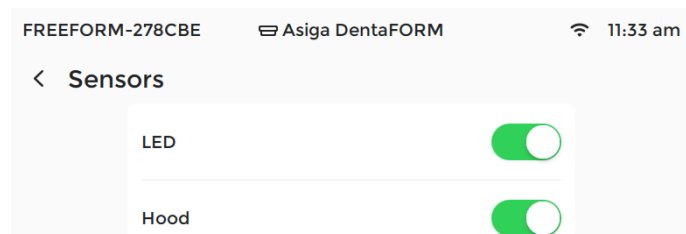

The sensor Status screen is accessed via Maintenance > Sensors > Status. This screen shows a status line for every optical sensor in the MAX 2 machine. Each line will provide the current state of the sensor.

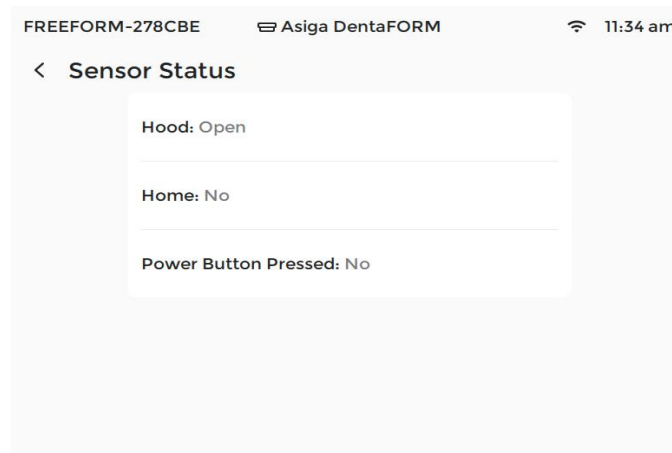

Material Analysis

The Spot Timer menu item is accessed via Settings > Tools > Material Analysis.

The Spot Timer is used to display a spot image for a controlled time. The Spot Timer can be used for material exposure testing.

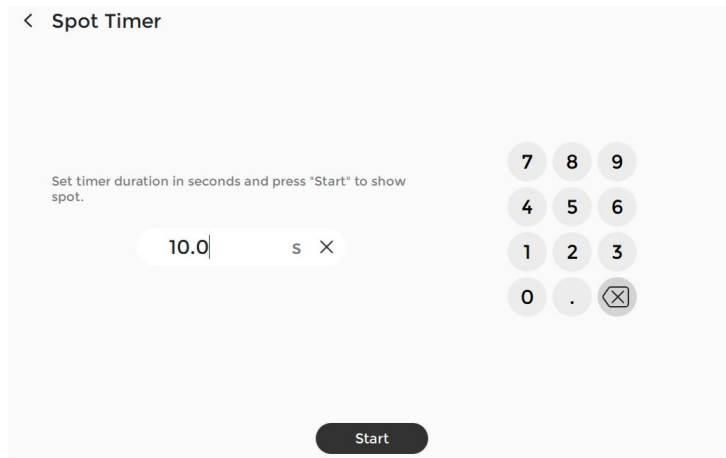

If additional control is needed over the spot image, the Material Test menu also has an option to control the spot radius and, if needed, the hole radius which allows changing the spot into an annulus.

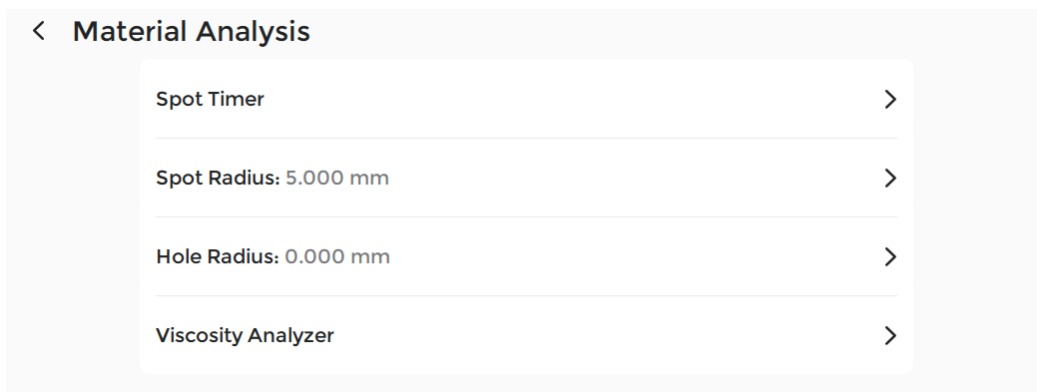

Viscosity Analyzer

The Viscosity Analyzer menu item may be used to determine the Viscosity Range of a material. The Viscosity Range parameter quantifies how viscous a material is. Its units are in millimeters. In practical terms, it measures the distance at which a surface exerts pressure against a target plate when moved towards it.

Go to Settings > Tools > Material Analysis > Viscosity Analyzer

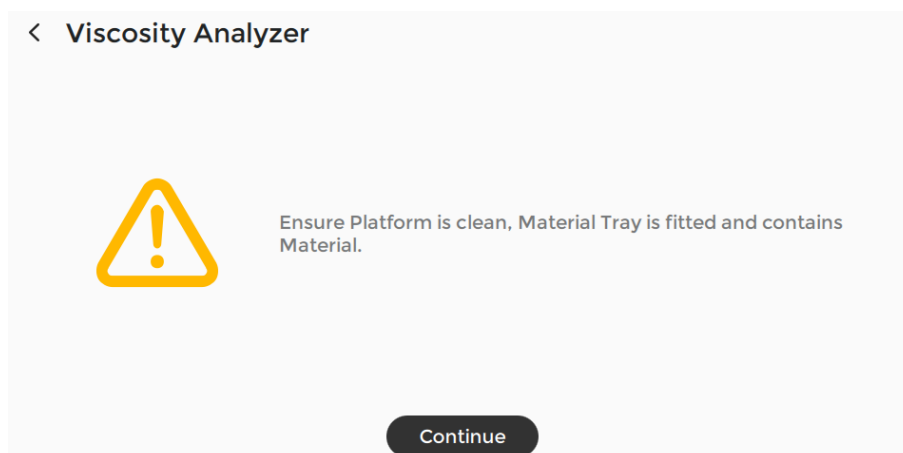

- Install a clean build platform into the machine.

- Install the resin material into the machine with the desired material.
- Define the settling time threshold. This can usually be left at the default value of 3 seconds.

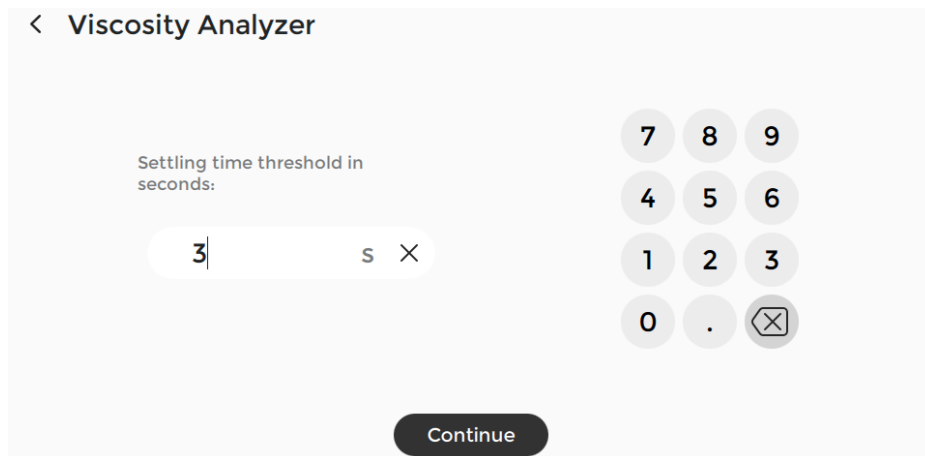

- Press "Continue".
- The platform will move down to a starting position 2 mm above the material film in the material. It will then move down 0.1 mm and wait until the material settles (i.e. when there is no force exerted on the material), recording the distance above the material film and the time it takes to settle. It will repeat this until the settle time is above the settling time threshold and then interpolate the distance above the material film which corresponds to the settling time threshold. The distance is then displayed as the viscosity range.
- Materials with higher viscosity will have a higher viscosity range. The determined viscosity range gives an approximation of the ideal value for the Viscosity Range parameter included in the Advanced Parameters section of the Build Wizard in Asiga Composer.

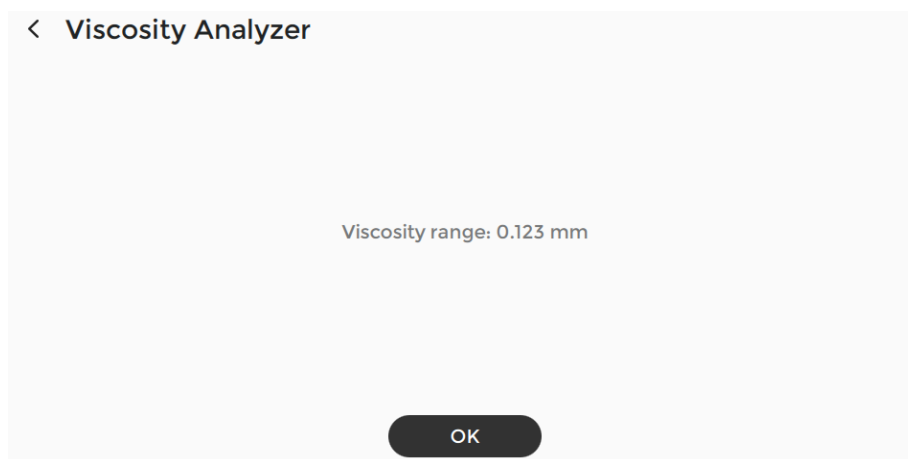

The data recorded that is used to determine the viscosity range is logged to "Debug Information" which may be accessed through the "System Information" tab of the web interface.

Clear User Data

The Clear User Data menu item deletes all pending jobs in the build queue and the current build. It also clears the BuildLog.ini file which records the attributes of recent jobs built on the machine.

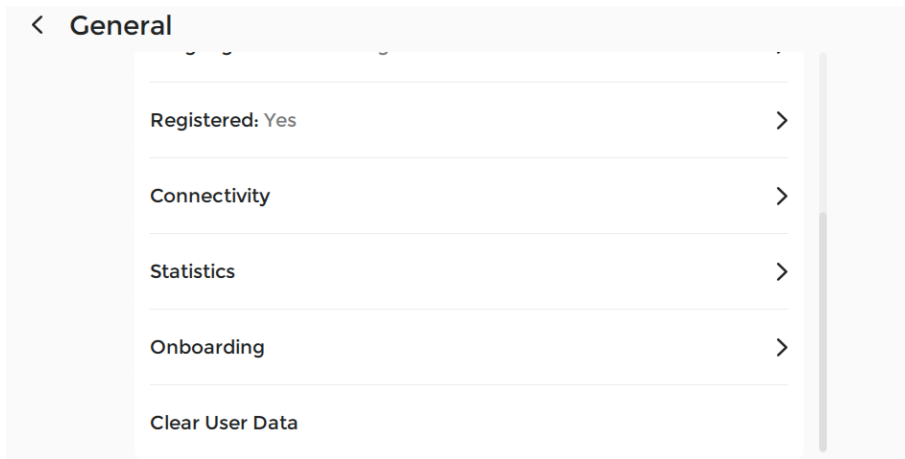

This function may be used when the machine is sold or confidential build jobs are on the machine.

Platform Calibration

Correct operation of the MAX 2 requires:

1. The build platform to be parallel to the glass window; and
2. The build platform to be in contact with the glass window when the vertical axis position is set to zero.

This is accomplished by performing the Platform Calibration procedure.

The Platform Calibration is done in the factory before the machine is shipped. However, it is recommended to recalibrate this position after the machine is transported or every few months. Poor zero calibration can result in models not attaching to the build platform.

To calibrate the zero position:

1. Install the build platform onto the vertical axis bracket.
2. Tighten the Build Platform Release Knob to secure the build platform in place.
3. Go to menu item Settings > Hardware > Smart Positioning System (SPS) > Platform Calibration & follow the prompts.

Validate Parallelism

A dome nut may be used to test how parallel the platform is to the glass. This is done by placing the dome nut within each corner under the platform and having the machine move down to measure the point of contact of each corner. The difference in contact heights can be used to determine the degree of parallelism.

1. Go to menu item Settings > Hardware > SPS > Validate Parallelism

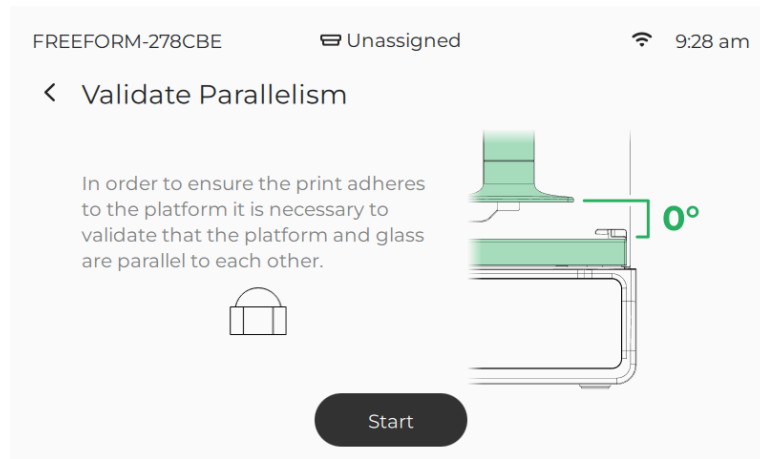

2. Install a clean build platform into the machine.

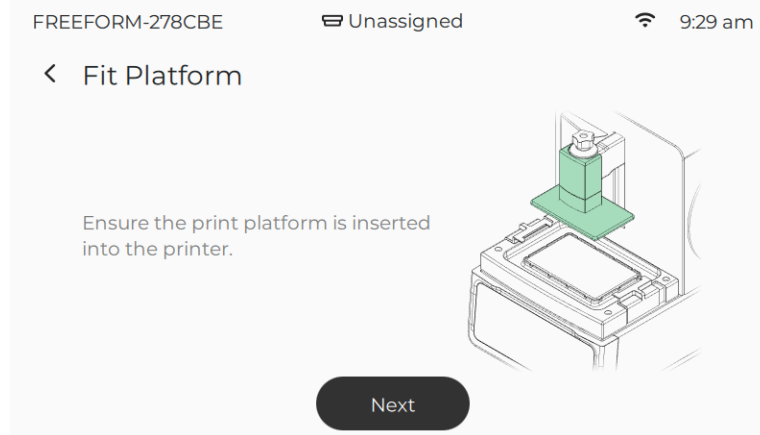

3. Remove the resin vat from the machine.

4. To commence, press "Next"

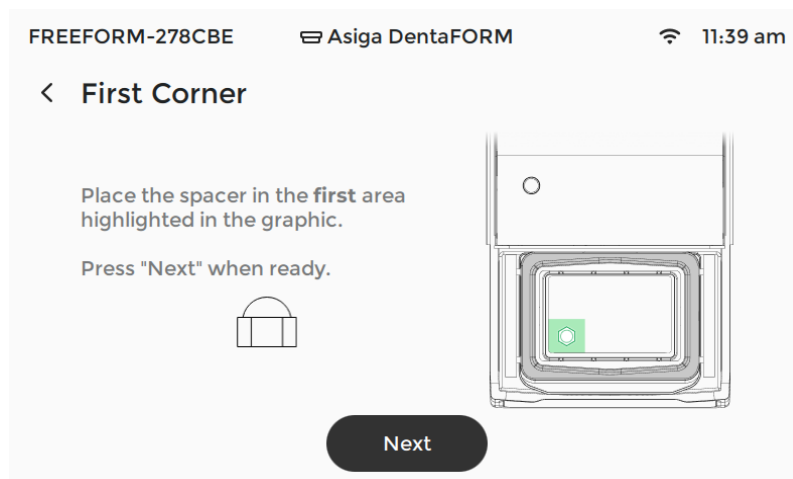

The platform will automatically move.

Ensure there is no debris and keep hands clear of all moving parts!

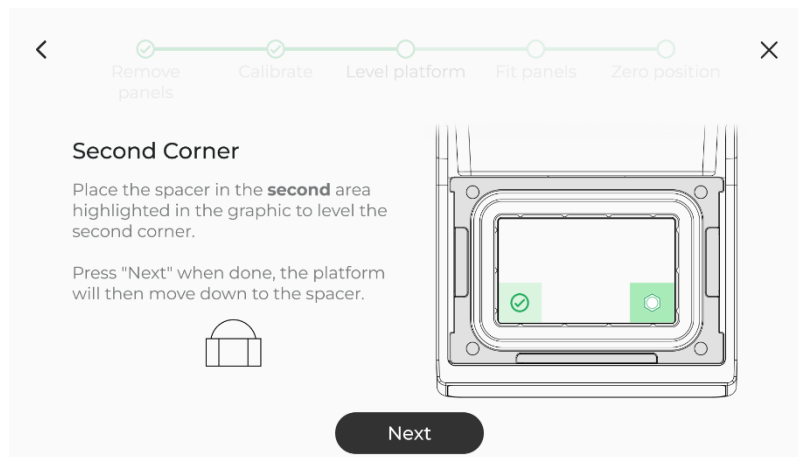
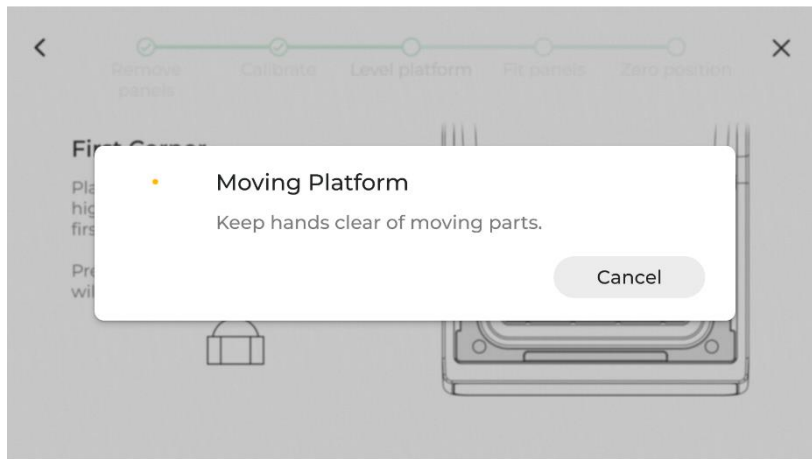

5. Press "Next"

The platform will automatically move.

Ensure there is no debris and keep hands clear of all moving parts!

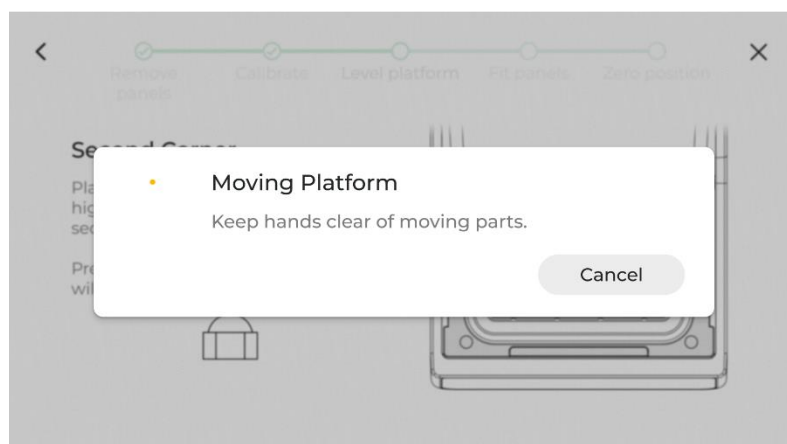

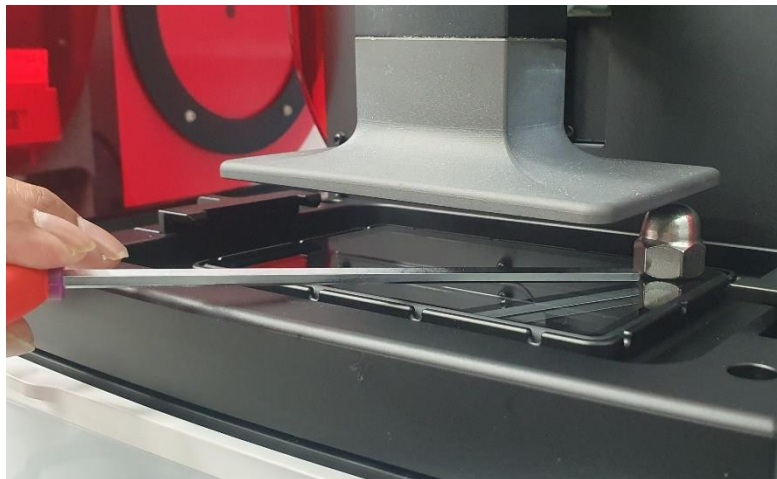
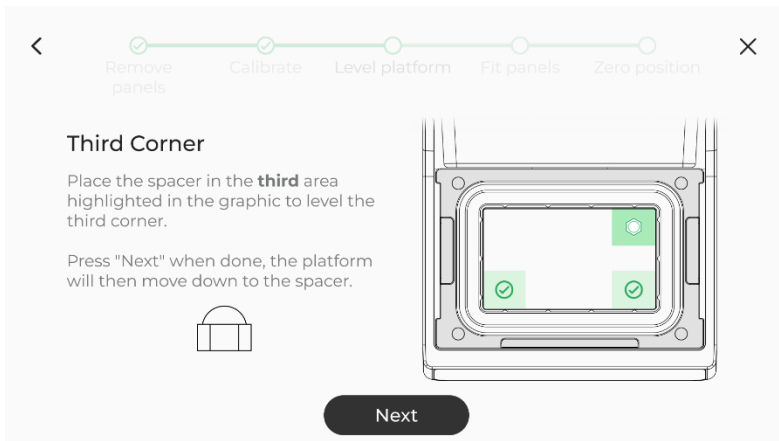

6. Move the dome nut to the front right corner. The dome nut should be resting within the glass and completely underneath the platform.
7. Press "Next"

The platform will automatically move.

Ensure there is no debris and keep hands clear of all moving parts!

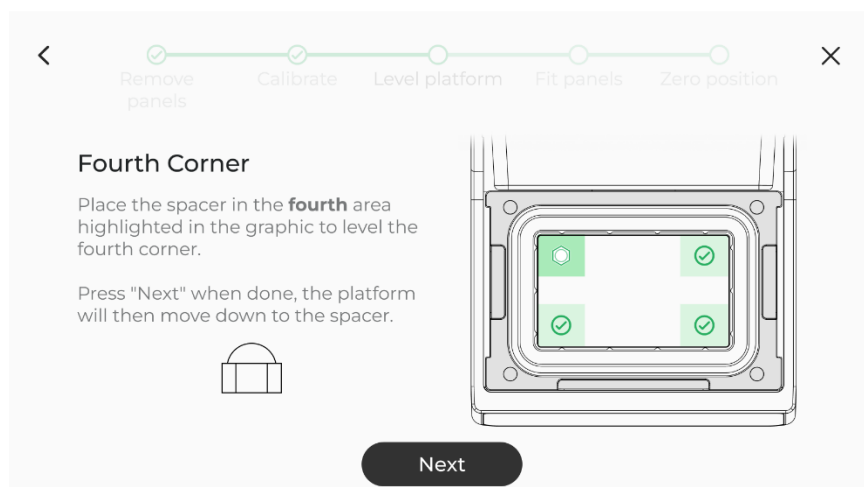

8. Press "Next"

The platform will automatically move.

Ensure there is no debris and keep hands clear of all moving parts!

If your Parallelism is within range, you should see the following screen:

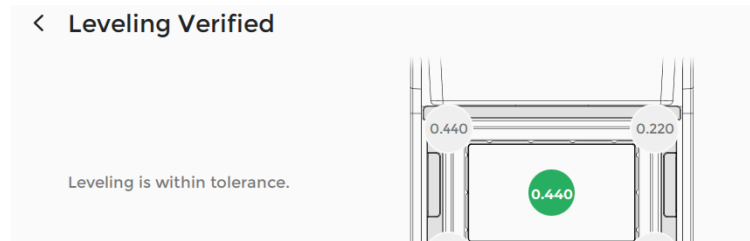

If your Parallelism is out of range, you will see the following:

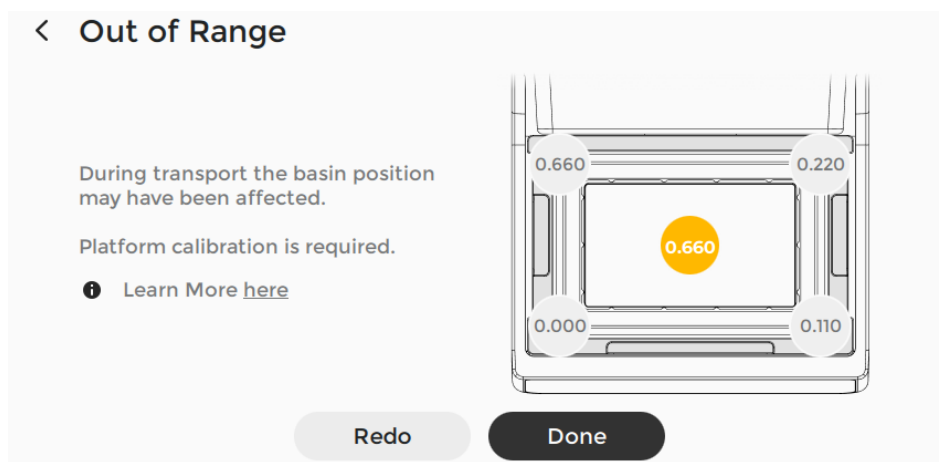

Please perform the Platform calibration & try again.

Service Mode

Service Mode shows all calibration and maintenance settings. By default items such as projector calibration are hidden from users.

The MAX 2 will indicate being in Service Mode by showing a red/white banner in the Status bar.

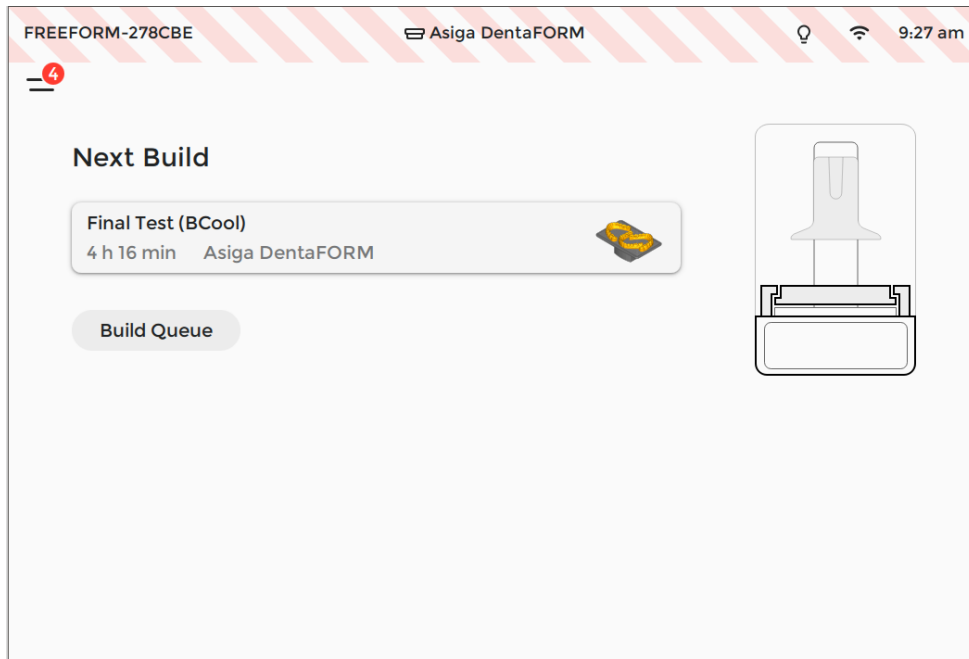

Service Mode will be automatically disabled when the machine is shutdown or restarted.

Enabling Service Mode is completed through the web interface.

Film Thickness

This is a service mode only option.

The menu item Settings > Hardware > Material Tray sets the material film thickness. Default material Film Thickness is 0.17 mm

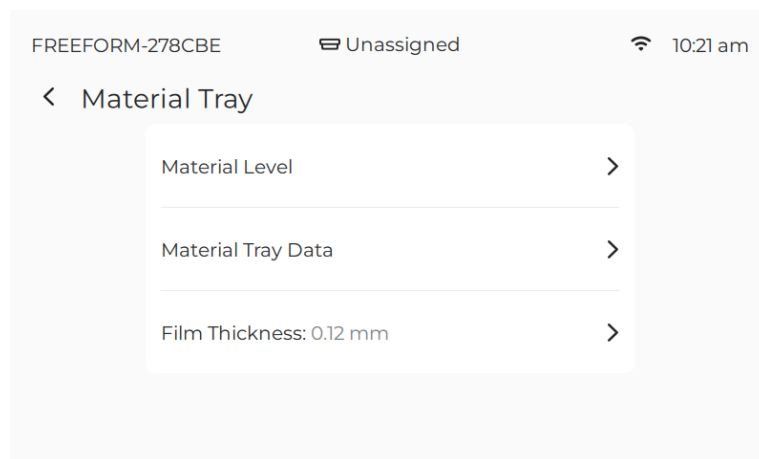

Calibration of the internal radiometer requires an external reference radiometer sensitive to light wavelengths in the range 350 nm to 450 nm. The image below shows a 3D printer system and an International Light ILT2400 Optical Meter. The person performing the calibration should wear UV safety glasses.



Warning

UV light will be emitted. Avoid direct exposure of eyes and skin. Close the machine hood, or wear the UV safety glasses at all times.

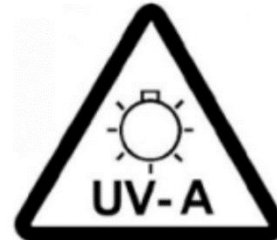

Calibrate Radiometer

This is a service mode only option.

To calibrate the MAX 2's internal radiometer:

Go to menu item Settings > Hardware > Projector > Calibrate Radiometer. Click "Continue" at the warning screen.

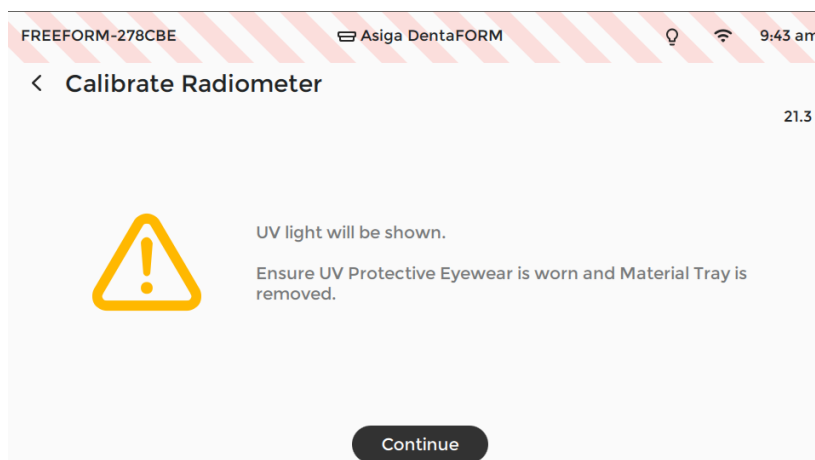

Hold the radiometer head over the build aperture so that the sensor is in the build area.



Note the value the external radiometer is reading. Ensure the wavelength setting of the radiometer corresponds to the LED wavelength of your MAX 2.



Enter the value the external radiometer is reading in the menu and press "Next".

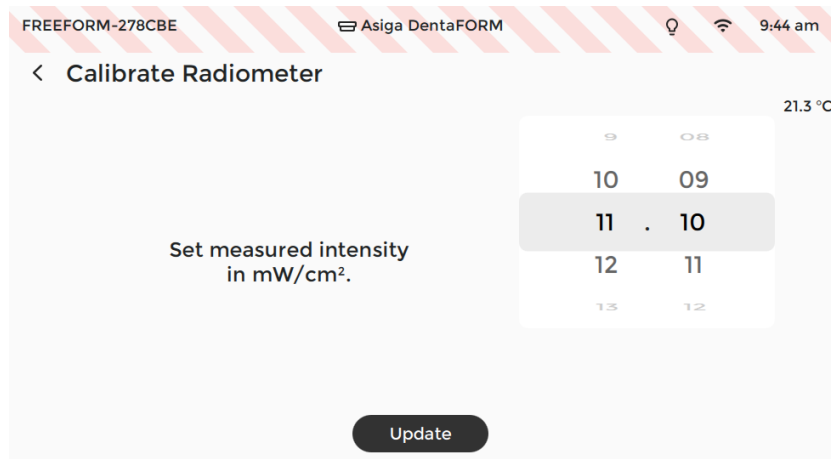

Press Update to confirm the measured intensity.

The internal radiometer will automatically be normalized to improve the radiometer response across the image area by illuminating different areas and measuring the change in radiometer readings. This will take less than 8 seconds to complete.

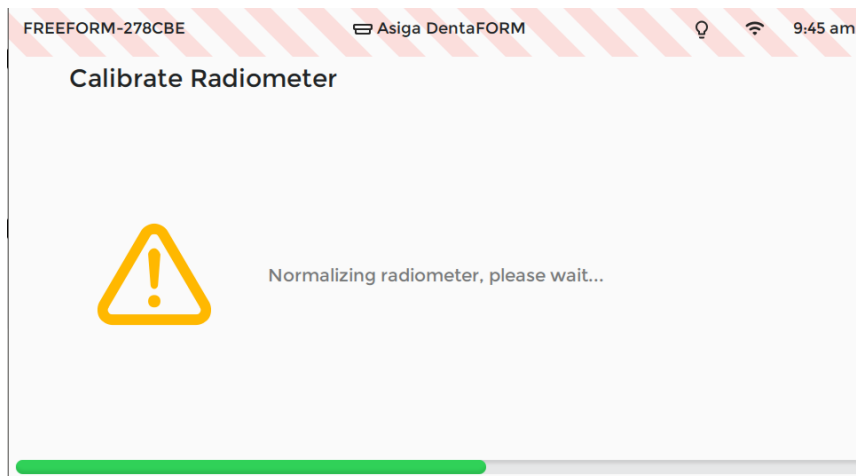

Normalize Radiometer

This is a service mode only option.

The Normalize Radiometer menu can be accessed by going to Maintenance > Service > Normalize Radiometer and is used to configure radiometer normalization.

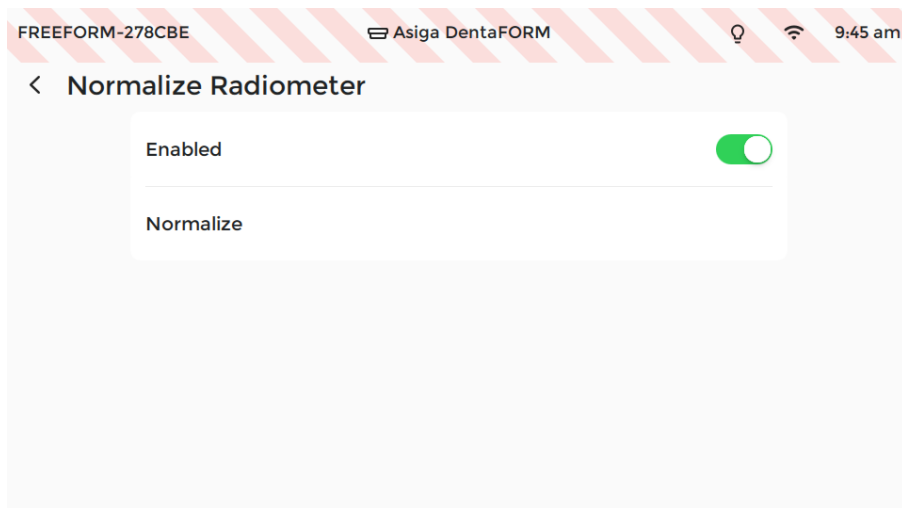

The Enabled toggle controls whether to use previously recorded normalization readings to improve the radiometer response across the image area. This does not need to be changed at all. It will be automatically enabled after performing the radiometer normalization process either automatically after Calibrate Radiometer is completed or manually normalizing by clicking Normalize.

Warning

UV light will be emitted. Avoid direct exposure of eyes and skin.
Close the machine hood, or wear the UV safety glasses at all times.

To perform radiometer normalization:

Press Normalize

Ensure UV protective eyewear is worn and the build tray is removed.

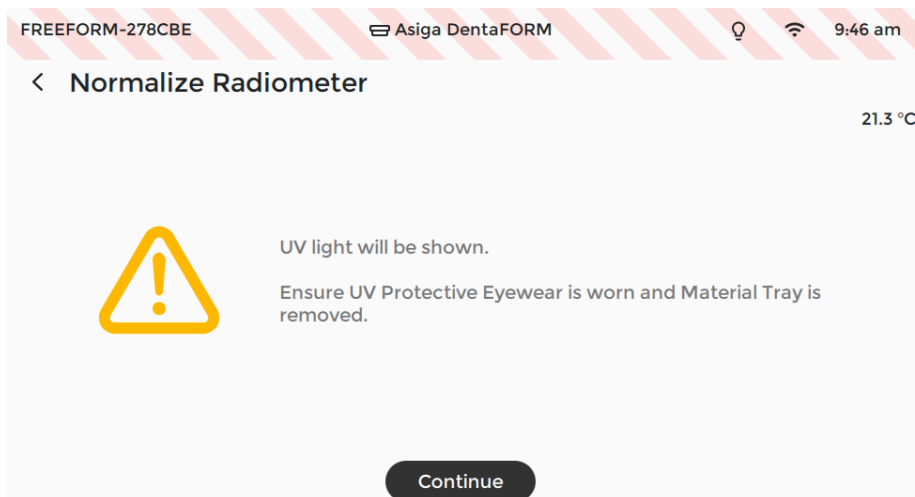

Press "Continue".

The internal radiometer will automatically be normalized to improve the radiometer response across the image area by illuminating different areas and measuring the change in radiometer readings. This will take less than 8 seconds to complete.

Calibrate Position Encoders

This is a service mode only option.

The MAX 2 uses four position encoders to measure pressure. These are calibrated at the factory and should not need to be recalibrated unless a position encoder been replaced.

Go to menu item Settings > Hardware > Smart Positioning System (SPS) > Calibrate Encoders

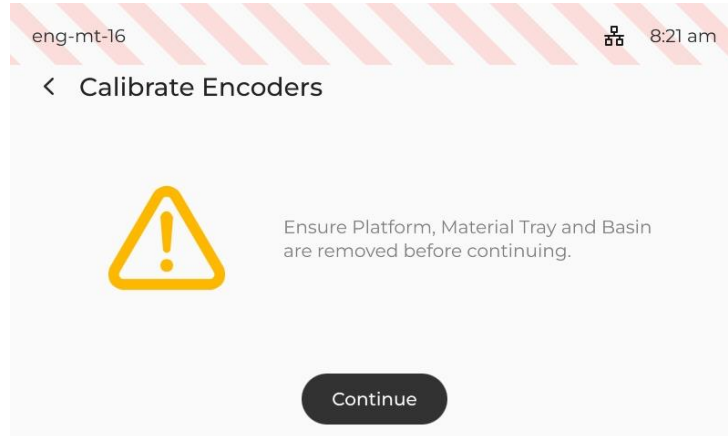

- Remove four grommets located in each corner of the Basin.
- Remove the 4 black screws which hold the basin in place.
- Remove the basin by lifting it with both hands and place it aside.
- Press "Continue".
- Enter weight of the calibration object in kg and press "Next".

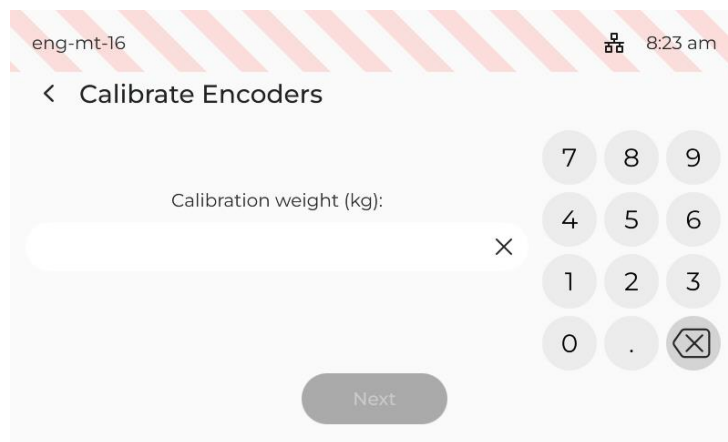

Place the calibration weight onto the front left position encoder (the calibration weight should only be touching the position encoder and not any other part of the machine). A square indicator is shown on the display for each position encoder. The indicator for the current position encoder will flash white.

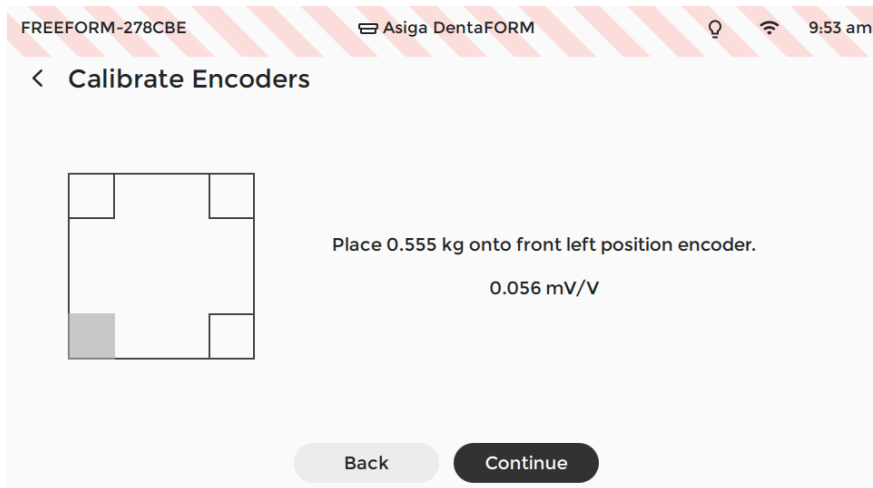

Once the calibration weight has been placed on the position encoder, the indicator should change to solid green.

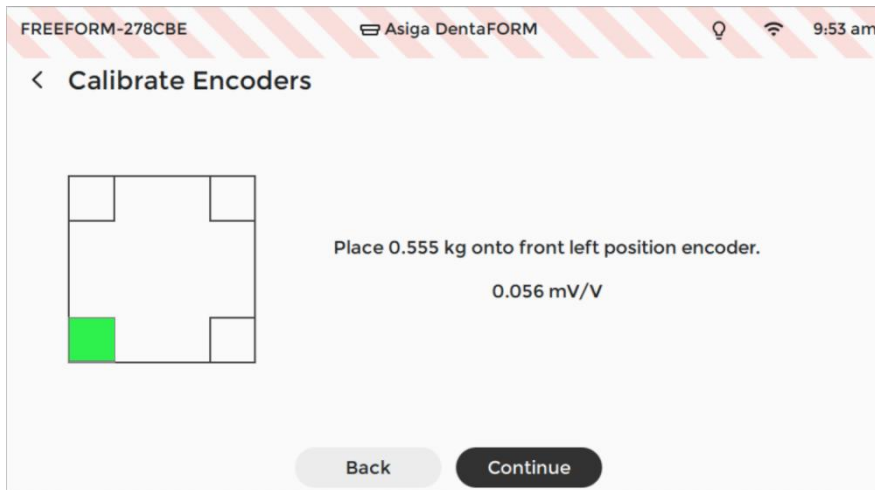

If the mV/V value has not increased enough, it will stay flashing white and pressing "Continue" will change the indicator to solid red to indicate the calibration for the position encoder has failed. Press Continue.

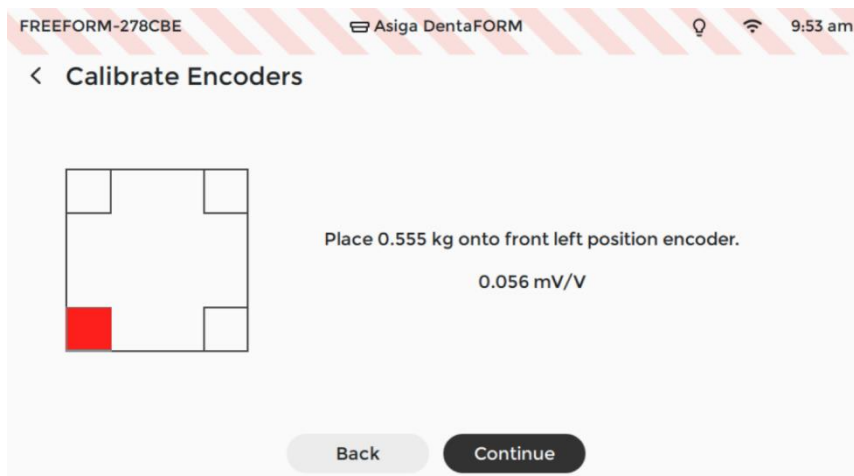

Move the calibration weight to the other encoders until all four are green.

If all of the position encoders were successfully calibrated, all indicators will be green and you can proceed to reattach basin and tighten the 4 black screws which hold the basin in place. Do not insert the build tray. Press "Finish".

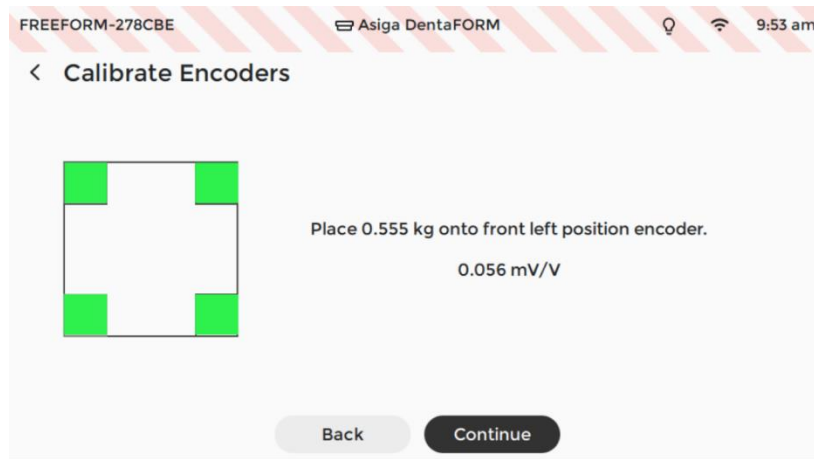

If calibration of one or more position encoders failed, then the screen will flash red with the indicators for the failed position encoders in red

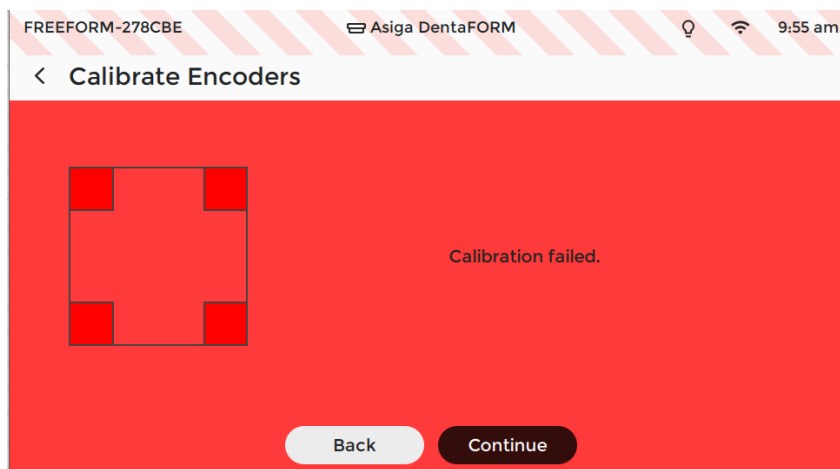

Press Back to go back to the previous screen or press the back arrow to go back to the menu. You may press Continue but the machine will not function correctly. After pressing Continue, reattach the basin and tighten the 4 black screws which hold the basin in place. Do not insert the build tray. Press "Finish".

Calibrate Deflection

This is a service mode only option.

The MAX 2 uses four position encoders to measure deflection of the glass window. The deflection is calibrated as follows:

Go to menu item Settings > Hardware > Smart Positioning System (SPS_ > Calibrate Deflection.

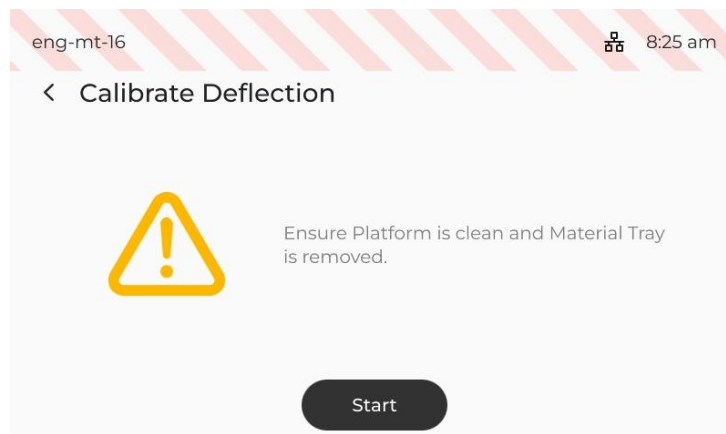

- 1) Install a clean build platform into the machine.
- 2) Install the resin material with material into the machine.
- 3) Press “Continue”.

The build platform will lower down into the material until a 0.1 mm gap is achieved and then show the LED for 60 seconds. The exposure will fill the gap between the platform and the tray film with solid resin. The build platform will then be pushed downward to measure the deflection.

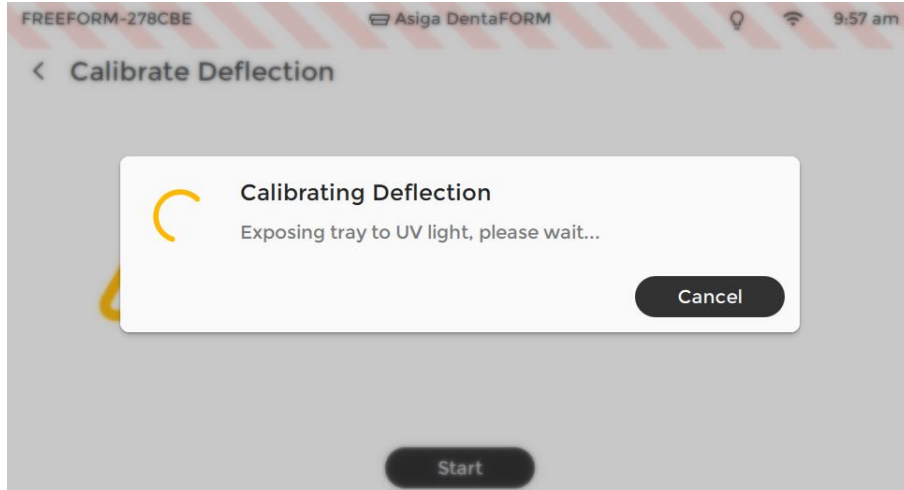

The process can be canceled at any time by pressing the “Cancel” button.

When the process is finished, you will be prompted to remove exposed layer from build platform.

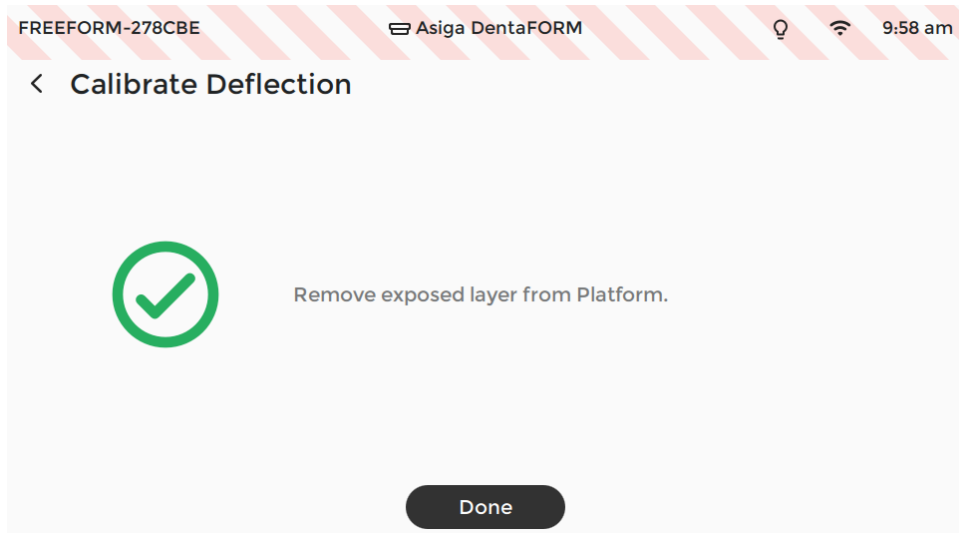

Remove the exposed layer from the Platform and press OK when finished.